

LIMITED WARRANTY

Limited Warranty: Subject to the limitations set forth below, THYSSENKRUPP ACCESS, 4001 East 138th Street, Grandview, Missouri 64030, warrants to the ORIGINAL PURCHASER ONLY that the Volant elevator (the "Elevator") and all parts used in the Elevator shall be free of defects in material and workmanship for a **two year period** commencing on the date of purchase. The self-addressed Limited Warranty card below must be completed and returned to THYSSENKRUPP ACCESS within 30 days from the date of purchase in order for this Limited Warranty to be activated. IF THE LIMITED WARRANTY CARD IS NOT RETURNED WITHIN THE FOREGOING TIME PERIOD, THIS LIMITED WARRANTY WILL BE NULL AND VOID.

Warranty Limitations: THE FOREGOING LIMITED WARRANTY IS THE SOLE AND EXCLUSIVE WARRANTY PROVIDED BY THYSSENKRUPP ACCESS, AND IS IN LIEU OF ALL OTHER WARRANTIES, WRITTEN OR ORAL, EXPRESS OR IMPLIED, ARISING BY OPERATION OF LAW OR OTHERWISE, BY THYSSENKRUPP ACCESS OR ANY OTHER PARTY, INCLUDING, BUT NOT LIMITED TO, WARRANTIES OF MERCHANTABILITY AND FITNESS FOR A PARTICULAR PURPOSE, WHETHER OR NOT THE PURPOSE HAS BEEN DISCLOSED AND WHETHER OR NOT THE ELEVATOR HAS BEEN SPECIFICALLY DESIGNED OR MANUFACTURED FOR BUYER'S USE OR PURPOSE. No person has been authorized to provide any other warranty or to assume any other liability with respect to the Elevator except by written statement from an authorized officer of THYSSENKRUPP ACCESS. This Limited Warranty does not extend to any losses or damages incurred as a result of any of the following: misuse, neglect, accident, abuse, user's negligence, improper operation (operation not in accordance with User's Manual), fire, flood, acts of God, ordinary wear and tear, and damage during shipment, improper assembly, care or maintenance if performed by any individual other than an authorized Dealer of THYSSENKRUPP ACCESS. The remedies provided under this Limited Warranty do not extend to minor mechanical adjustments (such as tightening of nuts, bolts and screws).

Limitation of Liability: UNDER NO CIRCUMSTANCES SHALL THYSSENKRUPP ACCESS OR ANY OF ITS AUTHORIZED DEALERS BE LIABLE FOR LOSSES OR DAMAGES ARISING FROM DELAY IN PERFORMANCE, OR USE OR INABILITY TO USE THE ELEVATOR, REGARDLESS OF THE FORM OF THE CLAIM OR CAUSE OF ACTION (WHETHER BASED IN CONTRACT, INFRINGEMENT, NEGLIGENCE, STRICT LIABILITY, OTHER TORT OR OTHERWISE), AND IN NO EVENT SHALL THYSSENKRUPP ACCESS'S LIABILITY TO BUYER EXCEED THE PRICE PAID BY BUYER FOR THE ELEVATOR. BUYER AGREES THAT IN NO EVENT SHALL SELLER'S LIABILITY TO BUYER EXTEND TO INCLUDE INCIDENTAL, CONSEQUENTIAL, SPECIAL OR PUNITIVE DAMAGES. The term "consequential damages" shall include, but not be limited to, loss of use and loss or damage to property. Some states do not allow limitations on how long an implied warranty lasts or the exclusion or limitation of incidental or consequential damages, or legal remedies, so these above limitations may not apply to you.

Claims: THE SOLE AND EXCLUSIVE REMEDY FOR BREACH OF THE LIMITED WARRANTY HEREUNDER SHALL BE LIMITED TO REPAIR OF THE DEFECT OR REPLACEMENT OF THE ELEVATOR WITHOUT CHARGE. Claims for defects in material and workmanship under this Limited Warranty must be made within the warranty period set forth above by written notification to the authorized THYSSENKRUPP ACCESS Dealer from which the Elevator was purchased. The written notice must include a description of the defect complained of, along with a copy of the invoice or other proof of purchase and the serial number of the Elevator. The authorized Dealer will notify THYSSENKRUPP ACCESS of the claim, and either the Dealer or an authorized THYSSENKRUPP ACCESS technician will, at THYSSENKRUPP ACCESS'S option, repair or replace the Elevator at Buyer's premises without charge for materials. Buyer may engage a third party other than THYSSENKRUPP ACCESS or an authorized THYSSENKRUPP ACCESS Dealer or technician to repair or replace the Elevator or to cure any defects in material and workmanship that would otherwise be covered under this Limited Warranty. HOWEVER, THIS LIMITED WARRANTY DOES NOT COVER ANY CHARGES OR EXPENSES ASSESSED BY ANY SUCH THIRD PARTY OR COMPANY PERFORMING SUCH REPAIRS OR REPLACEMENT WORK. COSTS FOR PARTS THAT ARE NOT GENUINE THYSSENKRUPP ACCESS PARTS, AND/OR DAMAGES TO THE ELEVATOR CAUSED BY THE USE OF NON-GENUINE THYSSENKRUPP ACCESS PARTS OR BY THE PERFORMANCE OF A NON-THYSSENKRUPP ACCESS DEALER OR AUTHORIZED TECHNICIAN, ARE NOT COVERED UNDER THIS LIMITED WARRANTY.

This Limited Warranty gives you specific legal rights, and you may have other rights which vary from state to state.

ThyssenKrupp Access • 4001 East 138th Street • Grandview, MO 64030
www.tkaccess.com www.thelev.com

Learn about new products, services and features at
www.tkaccess.com



User's Manual and Warranty Information

ThyssenKrupp Access



ThyssenKrupp

Table of Contents

Introduction.....	3
Elevator Overview.....	4
Description of Features	5-7
Important Operating Notes.....	8
Maintenance	9
Installation	8-9
Troubleshooting	10-11
Limited Warranty.....	12

This User's Manual must be read and understood in its entirety -prior to attempting operation of equipment. All operating procedures must be followed and all cautions and warnings must be observed in order to avoid possible injury or property damage!

IMPORTANT
The Serial Number of your
Elevator is:

This serial number contains important information about your elevator. This number may be needed if the Volant Elevator requires replacement parts. Please keep it handy.

it can resume normal operation. An "A2" will continue to display while the car is descending to the floor

"A3" Indicates the drive unit has overheated due to frequent use. The Elevator will shut down wherever it is, and cannot move while the overtemperature exists. Once the drive unit cools, the Elevator will automatically descend to the next floor where it can resume normal operation.

"A4" Indicates the power line voltage into the home is too low (brownout), or too high for elevator operation. The elevator will remain out of service until the voltage returns to within normal range.

Some error codes will cause the L.E.D. display will flash the floor number at each floor on which the Elevator stops, indicating that a past abnormality has occurred. The indicator will flash continuously for 24 hours before returning to the normal display.

Before you call for service. . .

A quick check of the Operating Instructions in this manual may prevent an unnecessary service call. Before calling your authorized ThyssenKrupp Access dealer or other licensed, qualified professional for service, refer to the following checklist . . .

If the Elevator will not operate:

- Check that all doors and gates are completely closed.
- Verify the car stop switch is in the "run" position.
- If equipped, check that key switch is turned to the "run" position.
- Verify that power is "on" at the disconnect switch box.

If the Elevator does not operate after checking the above items, contact your local authorized ThyssenKrupp Access dealer for immediate service. Do not attempt to service the Elevator yourself. If your Elevator needs servicing, we recommend that you use only original replacement parts and hardware to maintain quality and performance.

TROUBLESHOOTING

The L.E.D. displays located on the hall stations and car operating panel provide troubleshooting information by flashing an error code when the Elevator's controller has detected a problem. The Elevator is disabled while the error code is flashing.

There are four display categories of errors that give rise to an "abnormal" display:

- Flashing lower case **"d"**
Indicates that a safety device is open (pit switch or car top stop switch, final limit switch, or slack rope switch). The elevator will not move until the fault condition is corrected. Contact an authorized ThyssenKrupp Access dealer or other licensed and qualified professional to correct the fault.
- Flashing **"E"** followed by a number
Indicates an equipment failure. The elevator will not move until the equipment is repaired. Contact an authorized ThyssenKrupp Access dealer or other qualified professional to correct the failure.
- Flashing **"C"** followed by a number
Indicates a protective shutdown. The controller has shut the elevator down to prevent equipment damage and possible entrapment. The elevator may attempt to move to the nearest floor. This may be caused by overloading the elevator. Contact an authorized ThyssenKrupp Access dealer or other qualified professional.
- Flashing **"A"** followed by a number
Indicates a condition preventing Elevator operation. "A" conditions may be corrected to the extent necessary to allow the Elevator to operate without a professional service call. However, a service call will be necessary to reset the position indicator.
"A1" Indicates emergency stop switch in the car is thrown. Turning the switch to "Run" will correct the error.
"A2" Indicates Elevator has stopped between floors, (due to an open car gate). When the gate is closed, the Elevator will automatically descend to the next floor where

(continued on page 11)

INTRODUCTION

Your Volant Elevator has been manufactured with the same precision and care that has been a tradition for decades at ThyssenKrupp Access. You can be proud of the fact that you join thousands of others who have chosen a ThyssenKrupp Access elevator for their homes.

In order to achieve the maximum functionality from your Volant Elevator, it is essential that you read this User Manual carefully and understand its contents prior to using the elevator. This User Manual has been prepared to provide clear, concise operating and maintenance instructions.

As you will soon discover, your elevator is easy to operate and has been designed for years of dependable and trouble-free operation when operated and maintained in accordance with this User's Manual. As with all electrical and mechanical equipment, proper operation by the user and periodic maintenance performed by a qualified professional is absolutely required in order for equipment to continue to perform as intended. Therefore, we recommend that maintenance and repair services for your Volant Elevator be performed only by an authorized ThyssenKrupp Access dealer or a qualified professional with expertise in the repair and maintenance of comparable elevator systems.

Please remember ... Only an authorized ThyssenKrupp Access elevator dealer has technicians who have been trained to install, maintain and repair ThyssenKrupp Access elevator systems and who use genuine replacement parts that properly fit your Volant Elevator. They are committed to providing quality service. Damages caused by non-ThyssenKrupp Access technicians or non-genuine replacement parts will not be covered under your Limited Warranty.

Dealer Information

Name: _____

Address: _____

Telephone No.: _____

If you have questions concerning the operation or maintenance requirements of your Volant elevator, please contact the local ThyssenKrupp Access dealer listed above or contact the ThyssenKrupp Access Service Department at 800-409-3349.

ELEVATOR OVERVIEW

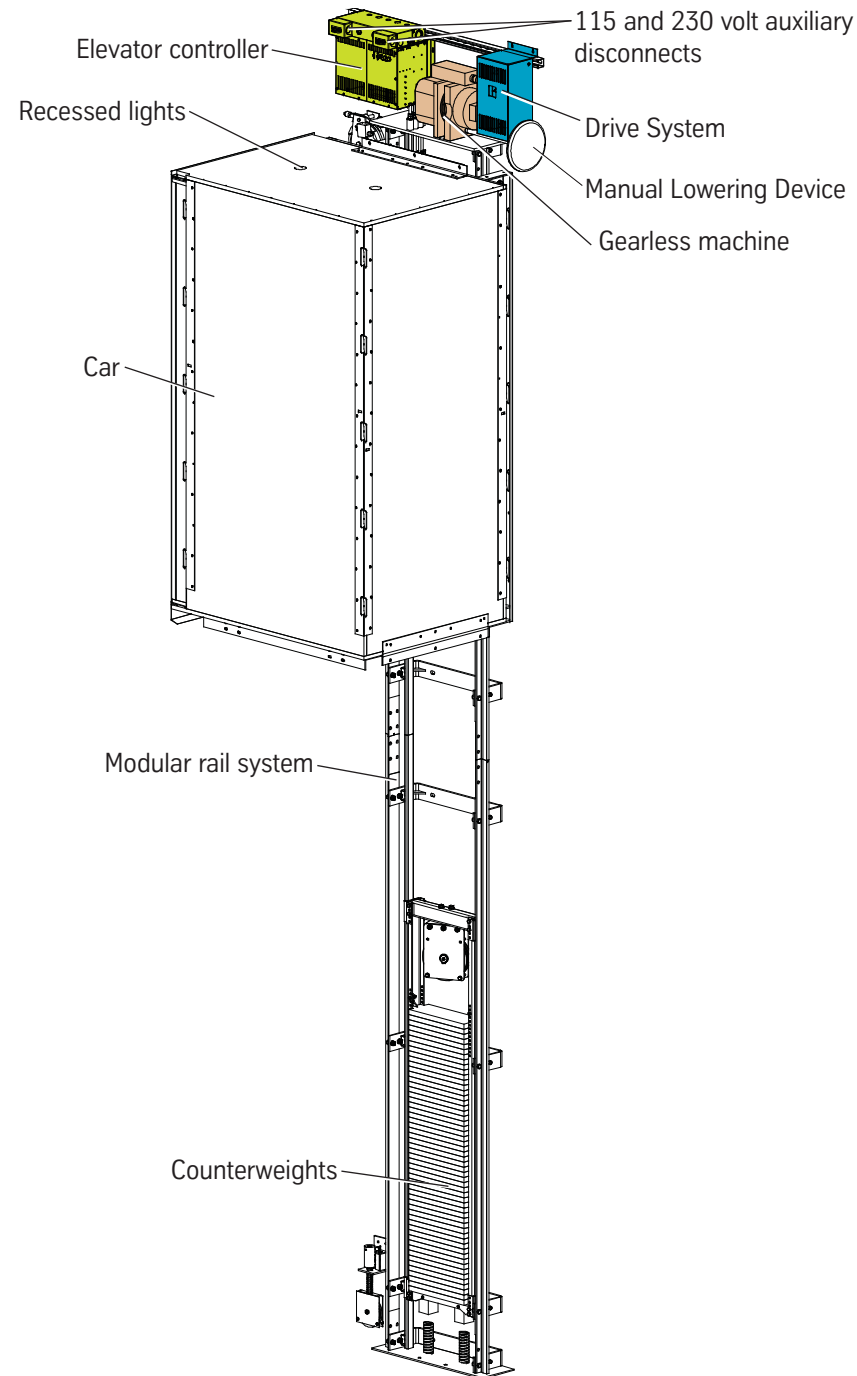

YOUR ELEVATOR. IT IS ESSENTIAL THAT THE APPROPRIATE LOCAL MUNICIPALITY IS CONTACTED WITH RESPECT TO COMPLIANCE WITH ALL LOCAL REGULATIONS.

DAMAGES CAUSED TO YOUR ELEVATOR, YOUR PROPERTY OR TO YOUR PERSON THAT ARE CAUSED BY FAILURE OF A NON-THYSSENKRUPP ACCESS CONTRACTOR TO FOLLOW THE INSTALLATION INSTRUCTIONS ARE NOT COVERED UNDER THE LIMITED WARRANTY SET FORTH IN THIS USER'S MANUAL. THYSSENKRUPP ACCESS HEREBY DISCLAIMS ALL LIABILITY (WHETHER ARISING IN CONTRACT, TORT (INCLUDING NEGLIGENCE AND STRICT LIABILITY) OR OTHERWISE) FOR DAMAGES TO PERSONS OR PROPERTY ARISING FROM OR IN ANY WAY CONNECTED WITH THE FAILURE OF A NON-THYSSENKRUPP ACCESS CONTRACTOR TO PROPERLY INSTALL THE ELEVATOR IN ACCORDANCE WITH THE INSTALLATION INSTRUCTIONS.

MAINTENANCE

Regular maintenance is essential in keeping your Elevator in proper operating condition. Please remember, you as the owner of this equipment, are responsible for making sure maintenance and upkeep are performed on a regularly scheduled basis.

We recommend that you to protect your investment by having only an authorized ThyssenKrupp Access dealer or other trained and qualified professional perform all required maintenance, service and repair work. Damage to your Elevator that results from improperly performed maintenance or repair work or use of non-genuine ThyssenKrupp Access parts is not covered under your Limited Warranty.

To assure proper operating condition of your Elevator, the items listed below should be inspected and/or serviced every six (6) months. Please ensure that your service technician follows the recommended list of maintenance procedures in order to avoid unnecessary damage to your Elevator.

- Tighten all fastening anchors.
- Inspect drive ropes and sheaves for wear. Ropes or sheaves must be replaced if showing signs of wear.
- Inspect travel cable for excessive wear or damage. Replace as necessary.
- Verify proper operation of all Elevator gate and hoistway door sensors.
- Verify proper operation of all car operating controls and hall station buttons.
- Equalize tension of ropes.
- Verify proper operation of automatic emergency lowering.



IMPORTANT OPERATING NOTES

The following operating guidelines must be observed at all times in order to prevent possible personal injury or damage to your Elevator or other property. ThyssenKrupp Access hereby disclaims all liability (whether arising in contract, tort, (including negligence or strict liability) or otherwise) for personal injury or property damage arising from user's failure to observe the following guidelines:

- Do not exceed maximum capacity of Elevator. See capacity tag inside Elevator.
- Do not bypass any safety control sensors.
- Do not lean against Elevator gates or hoistway doors.
- Close Elevator gate when not in use.
- Do not open the Elevator gate when the Elevator is in use. Attempting to open the Elevator gate while the Elevator is in use constitutes a safety hazard and could result in injury to passengers or bystanders. In addition, such attempts will cause the position indicators on the Elevator to flash continuously until the Elevator has been serviced. If the position indicators are flashing a past abnormality has been indicated, and service of the Elevator is required to reset the indicators.
- Do not use elevator to transport freight.
- Do not operate elevator if it has been damaged in any manner.
- In case of fire, do not use elevator.
- Be certain the elevator is at the proper floor level before entering or exiting.

INSTALLATION

PLEASE DO NOT ATTEMPT TO INSTALL YOUR ELEVATOR BY YOURSELF! A COPY OF THE ELEVATOR'S INSTALLATION INSTRUCTIONS HAS BEEN PROVIDED TO YOUR THYSSENKRUPP ACCESS DEALER AND DESIGNATED CONTRACTOR FOR USE IN THE INSTALLATION OF THE ELEVATOR. YOU MAY RECEIVE A COPY OF THE INSTALLATION INSTRUCTIONS AS A COURTESY FOR REFERENCE ONLY. PLEASE CONTACT YOUR LOCAL MUNICIPALITY FOR INFORMATION ON LOCAL REGULATIONS APPLICABLE TO THE INSTALLATION AND INSPECTION OF RESIDENTIAL ELEVATORS.

PLEASE NOTE: IN ORDER TO AVOID PERSONAL INJURY AND/OR PROPERTY DAMAGE, INSTALLATION OF YOUR ELEVATOR MUST BE PERFORMED BY AN AUTHORIZED THYSSENKRUPP ACCESS TECHNICIAN OR OTHER PROFESSIONAL WHO IS LICENSED AND QUALIFIED TO INSTALL THE ELEVATOR. IF YOU HAVE HIRED A NON-THYSSENKRUPP ACCESS TECHNICIAN TO INSTALL YOUR ELEVATOR, YOU MUST ENSURE THAT YOUR CONTRACTOR INSTALLS YOUR ELEVATOR IN ACCORDANCE WITH THE INSTALLATION INSTRUCTIONS.

PLEASE NOTE: LOCAL REGULATIONS MAY APPLY TO THE INSTALLATION AND INSPECTION OF

DESCRIPTION OF FEATURES

In order to avoid causing damage to your Volant Elevator (the "Elevator") or other property and to avoid personal injury, you must become familiar with the location and function of the features and options included on your Elevator before using. It is particularly important that you familiarize yourself with the safety devices and emergency controls described in bold text below. All Elevator users should have the ability to deactivate the safety devices during normal use and to activate the safety devices and emergency controls in the event of an emergency.

General

- Programmable logic controller (PLC) with digital signal processor
- Gearless machine drive
- Fully automatic operation
- 230V, 60 Hz, 20 amp single phase power source

Safety devices

- Upper and Lower Terminal Limits. Stops the Elevator in case the Elevator travels beyond the floor limit.
- Final Limits (2 upper, 1 lower). Stops the Elevator in case the Elevator travels beyond the terminal limit.
- Slack Rope Safety. Stops the elevator if one or both of the ropes fail.
- Car Top Stop Switch and Pit Switch. Located on top of the car and near the bottom of the hoistway, these switches are used to prevent operation of elevator during maintenance.
- Car Gate Safety Switch. PLEASE NOTE: The elevator will not operate if a gate is open.
- Hoistway Door Interlocks. PLEASE NOTE: The elevator will not operate if a hoistway door is open.
- Overspeed Governor. Stops the elevator if car moves too quickly or in the event of rope failure

Hall stations



Located near each hoistway door

- L.E.D. display shows the floor on which the Elevator is currently stopped.
- An illuminated ring around the button indicates the Elevator is in use.
- Press and release button to call Elevator to that floor. The ring around the button illuminates to acknowledge your call.
- If Elevator is already at your floor, press and release the button to unlock the door.
- The L.E.D. display also alerts you to complications that the control system may see. Refer to Troubleshooting on page 10 for more details.
- Some hall stations may be equipped with an optional key switch. On these systems, the key must be turned on before pressing the button.

Car operating panel



* Your operating panel may look different

Used to control the elevator from inside the car. Please familiarize yourself with the Emergency Stop Switch and Emergency Alarm Button for use from inside of the Elevator car in case of an emergency.

- L.E.D. display shows the floor on which the Elevator is currently stopped.
- Press and release a numbered button to send Elevator to that floor. The ring around the button illuminates to acknowledge your call.
- The L.E.D. display also alerts you to complications that the control system may see. Refer to Troubleshooting on page 10 for more details.
- PLEASE NOTE: The Emergency Stop Switch can be activated at any time to stop the Elevator's movement.
- PLEASE NOTE: The Emergency Alarm Button can be pressed to sound alarm at any time to alert others in the home of an emergency. A telephone is also provided in the car for emergency use.
- PLEASE NOTE: The Battery Backup Emergency Light, integrated into the top of the panel, illuminates during power failure.
- There is a phone integrated into the operating panel. You may use the phone to call for help in the case of an emergency inside the elevator
- Light switch to override the automatic car lights. With the light override switch turned "off", the car lights automatically turn on when the Elevator is in use and turn off after a period of non-use. To leave lights on constantly, turn the switch to "on".

Hoistway door interlocks



Keeps the hoistway door locked when the car is not there.

- The interlock locks the door 20 seconds after the door is closed.
- Press and release the hall station button to unlock the door, (if the elevator is at that floor).
- Surface mounted electromechanical interlock.
- PLEASE NOTE: The hoistway door interlock can be opened with a special key from outside the hoistway in case of emergency or for servicing. To unlock a door, insert the emergency release key into the hole in the door, (near the top) and pry up to release the interlock.



Emergency release key

Automatic car gate operator (optional)



Automatically opens the car gate when Elevator stops at a floor.

- Includes light beam safety curtain to keep gate open until path is clear.
- If Elevator is already at floor level, the gate automatically opens when the hoistway door is opened.
- A door open button is provided on the car operating panel.

Auto-Opener™ (optional)



Automatically opens hoistway door when Elevator stops at a floor.

- Mounts to wall near top of door on the hinge side.
- Works in conjunction with the automatic car gate operator.
- Automatically reverses when an obstruction is encountered.
- If Elevator is already at floor level, door can be opened by pressing hall station button.

Automatic homing

Approximately 5 minutes after the Elevator has been used, it automatically "homes" to a preprogrammed floor. The factory default is the top floor unless another floor was specified when ordered.

Car light switch

OFF - The car lights automatically turn on when a hall station button is pressed or the car gate is opened and turn off after 5 minutes of non-use of the Elevator.

ON - The automatic feature is disabled and lights stay on all the time.