

# PFLOW VERTICAL LIFTS

The Nation's Largest Manufacturer of Vertical Lifts

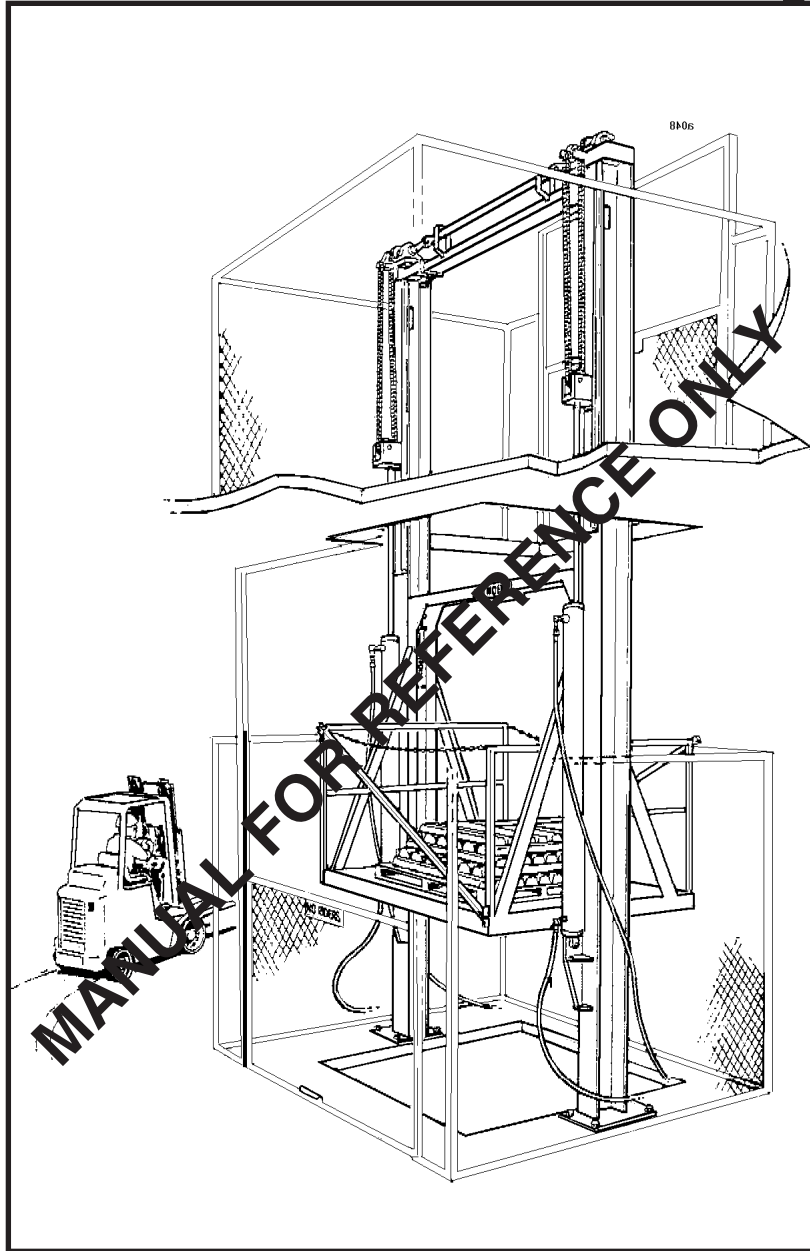

## OWNER'S MANUAL

### SERIES 21

### WITHOUT DECKLOCKS

THE ILLUSTRATIONS IN THIS MANUAL  
ARE NOT TO SCALE OR DETAIL AND  
ARE FOR REFERENCE ONLY

PFLOW INDUSTRIES, INC.  
5045 N. 35th Street  
Milwaukee, WI 53209

Phone (414) 462-8810  
Fax (414) 462-2673  
E Mail [pflow@pflow.com](mailto:pflow@pflow.com)

031303-21OND

---

## TABLE OF CONTENTS

TABLE OF CONTENTS.....	1
INTRODUCTION .....	3
SAFETY .....	4
Electrical Safety Precautions.....	5
COMPONENT LOCATION.....	6
MECHANICAL OVERVIEW.....	7
ELECTRICAL OVERVIEW .....	11
Operation .....	12
SERVICE .....	13
Maintenance & Troubleshooting of Pump Unit.....	13
Maintenance Schedule.....	14
Manual Release Valve.....	14
Flushing Hydraulic System.....	15
Safety Cam Inspection .....	17
TROUBLESHOOTING .....	18
PARTS.....	21
Motor Pump and Motor Assembly .....	21
Manifold Block Assembly.....	22
Adjustable Wheelblock Assembly .....	23
Upper Wheelblock Assembly (Phenolic).....	24
Lower Wheelblock Assembly (Phenolic).....	25
Upper Wheelblock Assembly (5 1/4 Steel Wheel w/Roller Bearing).....	26
Lower Wheelblock Assembly (5 1/4 Steel Wheel w/Roller Bearing).....	27
Upper Wheelblock Assembly (5 3/8 Steel Wheel w/Roller Bearing).....	28
Lower Wheelblock Assembly (5 3/8 Steel Wheel w/Roller Bearing).....	29
Clevis Assembly .....	30
LevelDeck Shaft Assembly.....	31
Adjustable Carriage Stop .....	32
Cylinder Assembly.....	33
Interlocks.....	35
Gate Status Switch.....	36
RECOMMENDED STORAGE REQUIREMENTS.....	37
ELECTRICAL TERMINOLOGY AND APPLICATIONS .....	38
WARRANTY .....	40
INSTALLATION QUESTIONNAIRE .....	41
ACCEPTANCE CERTIFICATION.....	42

(Cont'd Page 2)

---

## TABLE OF CONTENTS

APPENDIX.....	43
MATERIAL SAFETY DATA SHEETS	
Custom-Pak Products - Aerosol Paint	
Prime Coatings - Grey H.S. Primer	
Prime Coatings - High-Solids Blue Enamel	
Moore Flo Hydraulic - Product Data	
Moore Oil Company - Homan AW 32 Hydraulic	

## INTRODUCTION

Thank you for purchasing a PFLOW INDUSTRIES, INC., Series 21, Vertical Reciprocating Conveyor (VRC). As the nation's largest manufacturer of VRCs, we are confident that your unit will provide you with many years of reliable service.

**CODE REQUIREMENTS** - VRCs are NOT elevators. Your unit is designed for the movement of materials only, up to its rated capacity, from one level to the next. VRCs have their own national code (ANSI/ASME B20.1) and are specifically exempt from the National Elevator Code. All electrical designs and components are in accordance with National Electric Code (NEC) requirements. Local codes may require initial inspection of the installation and periodic inspection and testing of the unit.

Some states require special components and have specific guidelines regarding how the equipment must be installed, inspected, and tested. If we know in which state the equipment will be located, and if we are kept informed of state and local requirements, Pflow will incorporate the components into the order, as approved by the customer, and also provide any pertinent information, as called out on the general arrangement drawing, related to the installation of the equipment. We will not be on site for the testing, but we strongly advise that the installer be there.

If at any time you have questions about your state's requirements, please feel free to call.

## NOTE

*The information and illustrations in this manual are intended only as an aid to understanding the VRC's general installation. It does not cover every possible contingency or circumstance regarding non-standard options or site conditions.*

If you have a problem, call Pflow at (414) 462-8810, between 8:30 A.M. and 5:00 P.M., CST, Monday through Friday. Ask for the Product Support Department and have your serial number ready.

**Parts** - Pflow Industries maintains a complete stock of, or has access to, all replacement components. We keep detailed records of all equipment sold. If something is damaged in shipment, is defective or missing, contact us immediately.

**Service** - Our Product Support Department is available to assist your maintenance personnel with any questions or problems they may have regarding the equipment.

**Warranty** - Our warranty procedures can be found in the back of this manual. Prior authorization must be obtained from Pflow before commencing work of any kind.

**Feedback** - Let us know how we are doing. A questionnaire is included in the installation manual. Please fill it out and return it to us. We can't prevent a problem if we are not aware of it.

PFLOW INDUSTRIES, INC.,  
5045 N. 35th Street, Milwaukee, WI 53209  
Phone: (414) 462-8810  
Fax: (414) 462-2673  
E-mail: [pflow@pflow.com](mailto:pflow@pflow.com)  
Website: [www.pflow.com](http://www.pflow.com)

# 21 Series

---

## SAFETY

To ensure your safety and the safety of those around you, it is important that you read, understand, and follow ALL the safety precautions relative to a particular task. Safety precautions in this manual are labeled with the alert symbol followed by the word DANGER, WARNING or CAUTION.

### DANGER

When you see this symbol, it means that serious injury or death is likely to occur if the instructions are not followed carefully.

### WARNING

When you see this symbol, it means that the potential for personal injury is high if directions are not followed carefully.

### CAUTION

When you see this, it means that the potential for damage to the equipment is high if directions are not followed carefully.

### NOTE

*This term is used to provide additional information to help clarify instructions.*

### DANGER

**HIGH VOLTAGE.** Failure to follow proper procedures when performing electrical installation or service may result in serious injury or death.

### DANGER

**DO NOT ride this equipment.** Riding may result in injury or death. VRCs ARE NOT ELEVATORS.

### DANGER

**DO NOT walk or work under a raised platform.**

### DANGER

**If you can open a gate when the unit is not at that level, or the unit will operate with a gate open, a safety device is not working and could result in serious injury or death.**

### WARNING

**DO NOT operate the unit if either the gates or interlocks are not functioning properly.**

### CAUTION

Paint overspray on cylinder rod will damage seals and void warranty.

### CAUTION

**DO NOT exceed rated capacity.**

### WARNING

**If your Series 21 VRC is not equipped with decklocks, do not leave the carriage at the upper level when you have finished using the VRC.**

## Electrical Safety Precautions

### **⚠ DANGER**

Always assume that a circuit is not safe until you are sure that it is dead. Make sure that it cannot be energized after you start working on it. Follow OSHA procedures for locking out the control panel ANYTIME maintenance or service is being performed on the unit. Put a lock and tag on disconnects, breakers, and/or pulled fuses.

- Use a voltage tester on circuits - **DO NOT USE YOUR FINGERS**. Use fuse pullers to change a fuse; **NEVER** use fingers, pliers or screwdrivers. Covers on exposed electrical devices or wires **MUST** be installed to protect personnel from injury or shock.
- **ALL** metal connection boxes, switch boxes, starting boxes, transformer shells, and motor frames must be grounded to prevent shock to personnel.
- When using a portable electric meter, **DO NOT** connect one wire and leave other wires dangling loose. Anyone touching it will receive a shock through the meter.
- Before powering a circuit on, make sure that all is clear. This is necessary in order to protect personnel from injury and to prevent damage to the equipment.
- Avoid accidental contact with equipment or conductors which are known to be live or are **NOT** known to be dead. If it is necessary to work on equipment while it is hot, extra care must be observed. Always test and repair equipment that indicates a warning of unsafe conditions by giving a nonfatal shock. **NEVER** assume that because the warning shock is nonfatal, the next shock will also be nonfatal.
- **TAKE TIME TO BE CAREFUL!** Following safety precautions and using common sense will prevent injury, mutilation, or death.

## Safety Precautions When Working on Live Circuits or Equipment:

When electrical repair or maintenance work is required that prohibits de-energizing the circuits involved, extreme measures of safety must be used. The work should be accomplished only by well-supervised personnel who are fully aware of the dangers involved. Every care should be taken to protect the person performing the work and to use all practical safety measures. The following precautions **MUST** be taken:

- The person doing the work should not wear a wristwatch, rings, watch chain, metal articles, necklaces or loose clothing which might make accidental contact with live parts or throw some part of his body into contact with live parts.
- Clothing and shoes should be as dry as possible.
- Insulate the worker from ground by covering any adjacent grounded metal, with which he might come in contact, with insulating material. Suitable insulating materials are dry wood, rubber mats, dry canvas, dry phenolic material, or even heavy, dry paper in several thickness. Be sure that it has no holes and no conducting materials embedded in it. Cover sufficient area so that adequate space is permitted for worker movement.
- Cover working metal tools with an insulating rubber tape (not friction tape) as much as is practical.
- **DO NOT** stick a bare screwdriver or other tool into a hot fuse box.

## COMPONENT LAYOUT - STRADDLE

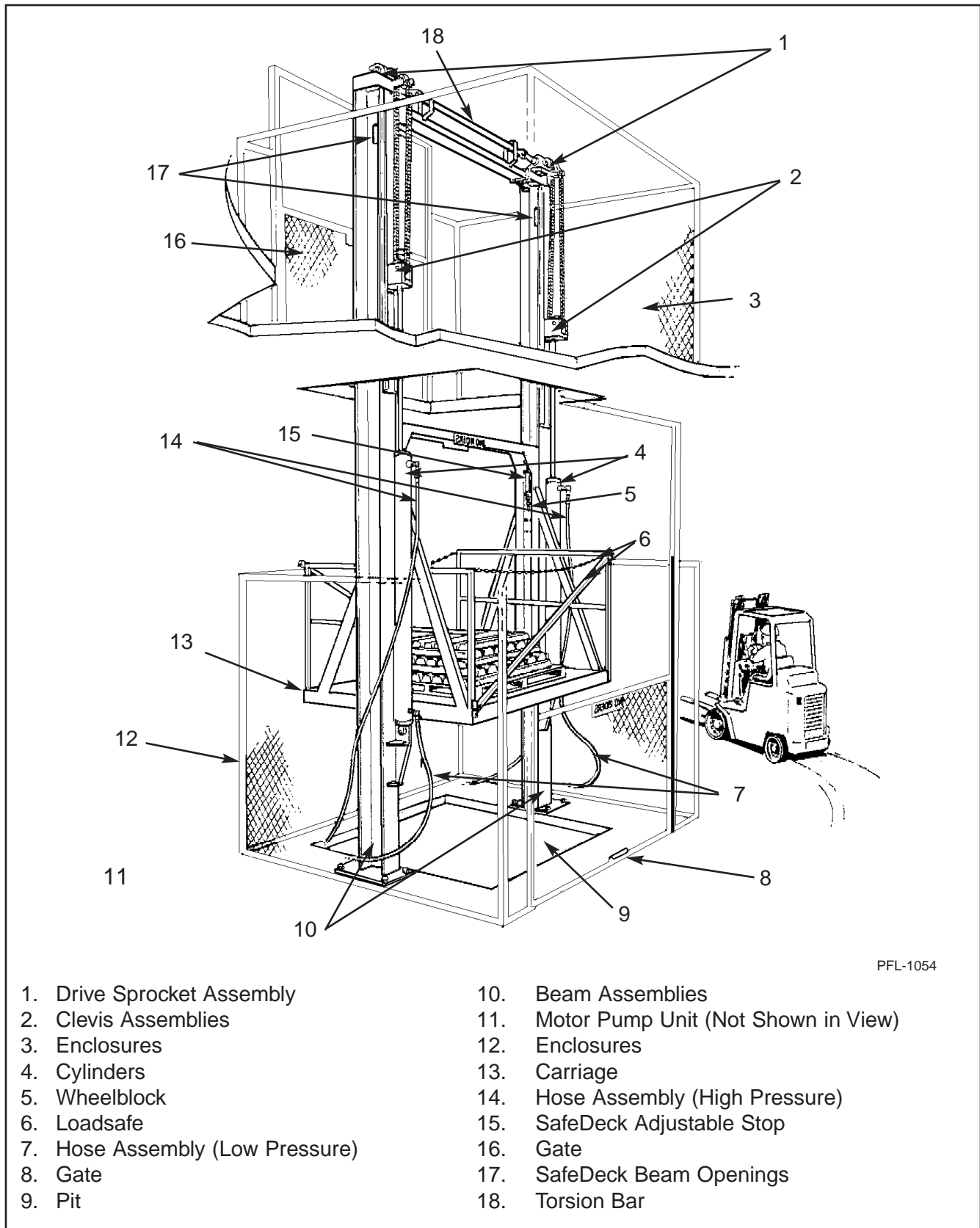

PFL-1054

Figure 1

## MECHANICAL OVERVIEW

Each unit is a customized application of the product. Individual components will vary according to the capacity of the unit, customer's specification, and options chosen.

The following is an overview of the various components and their purpose. Exploded view illustrations are shown in other sections of this manual.

The **FRAME** consists of two vertical upright beams. These beams are anchored at the base plates to the first level and positioned by the header/torsion bar assembly at the top and bracing at other levels.

The **LEVELDECK** feature consists of a torsion bar and header across the top of the beams.

The **CARRIAGE** consists of a platform, framing, four wheelblocks, and either railings, enclosures, or sides.

**LOADSAFE**, our exclusive safety barrier, is secure, easy-to-position, and self-storing.

A **SAFETY GATE** or door must be provided at each level and opening. Whether a Pflow Industries product or existing door or gate, they must be interlocked, both mechanically and electrically, with the operation of the unit. This is to prevent movement of the platform when a gate is open or opening of a gate or door when the lift is not at that level.

In accordance with ANSI B20.1, Pflow Industries supplies standard **ENCLOSURE PANELS** to be installed around the unit as required by site conditions. Our panels are manufactured of 1 1/2" angle frames and 15 gauge flattened expanded metal which will reject a ball 2" in diameter. Our standard panels are 8 feet high. Total height includes 1 1/2" legs for mounting to the floor. Extended height applications are available.

There are two configuration types available for this model. "Straddle" is when a column is located on each side of the carriage. This is shown in Figure 1.

"Cantilever" is when both columns are at the back. There is no difference in the operation or maintenance of the two models.

Pflow Industries provides a "NO RIDER" sign for each gate and the carriage. A "CAPACITY" sign shows the maximum allowed load that this model is designed to accept. As a reminder, i.e., "SAFETY SYSTEM DOES NOT INCREASE OPERATING CAPACITY" and "DO NOT EXCEED RATED CAPACITY" signs are also provided.

The **HYDRAULIC MOTOR/PUMP UNIT** consists of a motor, gear pump, flow control valve, relief valve, reservoir, accumulator, air and oil filters. This unit is located separately from the lift and connects by hoses to the cylinders mounted on the beam. Recommended placement is within 10' of the unit. See Figure 2.

### NOTE

*For servicing and safety purposes, we recommend locating the pump unit outside of the enclosures.*

### NOTE

*The location of the pump unit may present a problem with the operation. Please consult our Product Support Department before making a change.*

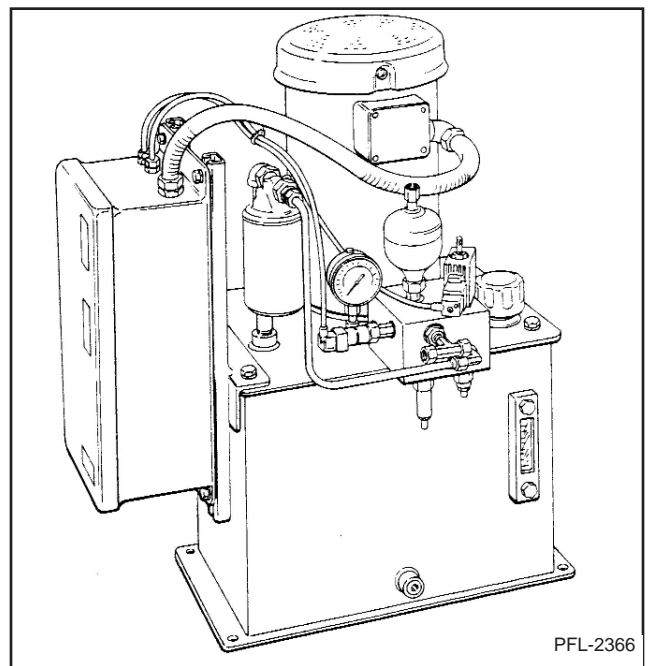
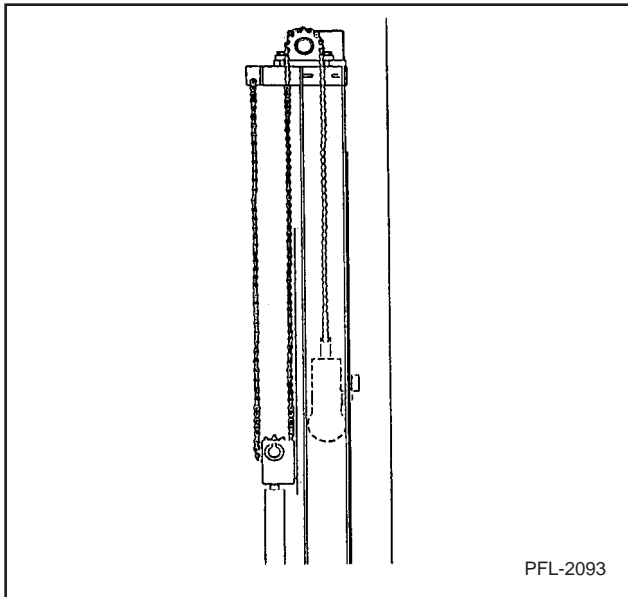

Figure 2

# 21 Series

The **LIFTING COMPONENTS** consist of two hydraulic cylinders, each with a clevis sprocket assembly attached to the piston of the cylinder. A second drive sprocket assembly is mounted at the top of each beam.

The lift chain is connected at the deadhead, loops around the clevis sprocket, up to the drive sprocket, and connects to a wheelblock assembly bolted to the carriage. See Figure 3.



**Figure 3**

The **WHEELBLOCKS** are bolted to the carriage uprights. During travel the wheels ride inside the beams and guide the carriage. See Figure 4.

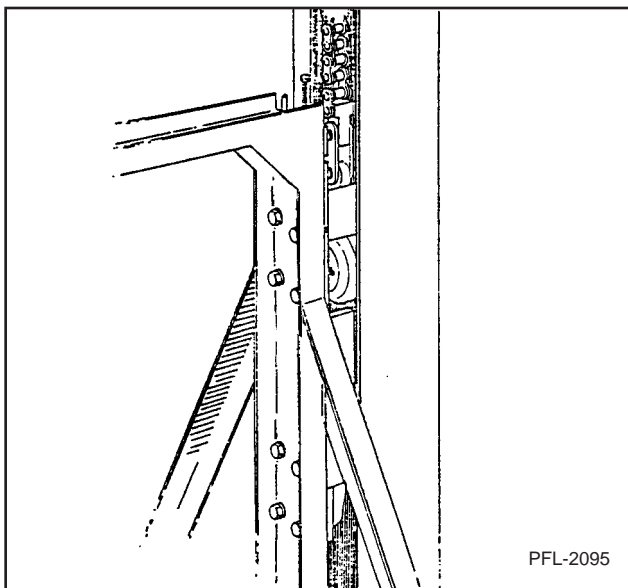

**Figure 4**

Each wheelblock has a mounting block, a wheel, and two guide rollers. See Figure 5.

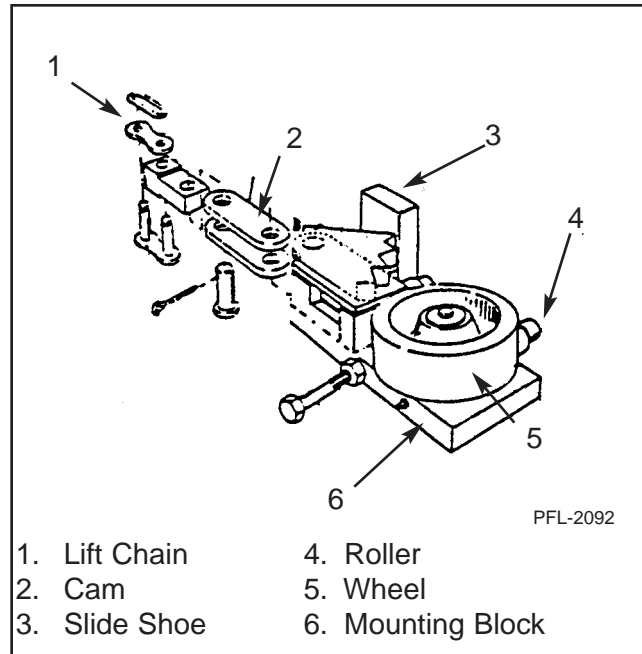

**Figure 5**

Each upper wheelblock also has a steel **SAFETY CAM** with teeth cut into it and a shoe. This cam is pivoted on the mounting block and is spring loaded. The lift chain connects to this safety cam, and all lifting action is through it. Should the chain break or go slack, the cam will be pivoted by its spring into a jam position with the track to stop the carriage from falling. The guide shoe on the outside of the track helps to wedge the track between the shoe and cam teeth.

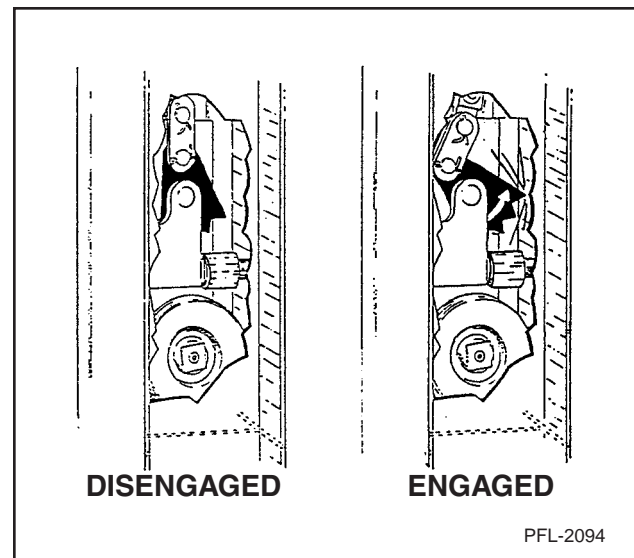
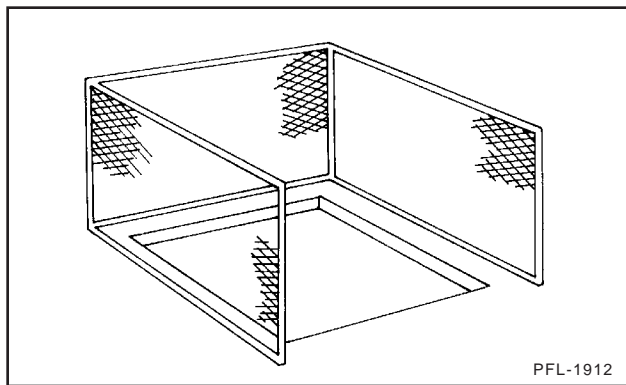

**Figure 6**

**SAFEDECK** is Pflow Industries, Inc. exclusive design for locking the carriage at an upper level. When the carriage is sent to the upper level, it proceeds past that level and activates the level limit switch. The motor shuts off, the dump valve opens, downward travel begins, and the DeckLocks engage.

When the unit is called to return to the first floor, the carriage will raise to unlock the DeckLocks and proceed to the first floor.

In accordance with ANSI/ASME B20.1, Pflow Industries supplies standard **ENCLOSURE PANELS** to be installed around the unit as required by site conditions. See Figure 7.



**Figure 7**

The panels are manufactured of 1-1/2" angle iron frames and 15-gauge flattened expanded metal which will reject a ball 2" in diameter. Our standard panels are 8' tall.

A safety **GATE** or door must be provided at each opening in the lift area at each level. The gate must be interlocked both mechanically and electrically with the operation of the unit. This prevents movement of the platform when a gate is open and the opening of a gate when the lift is not present at that level. See Figure 8.

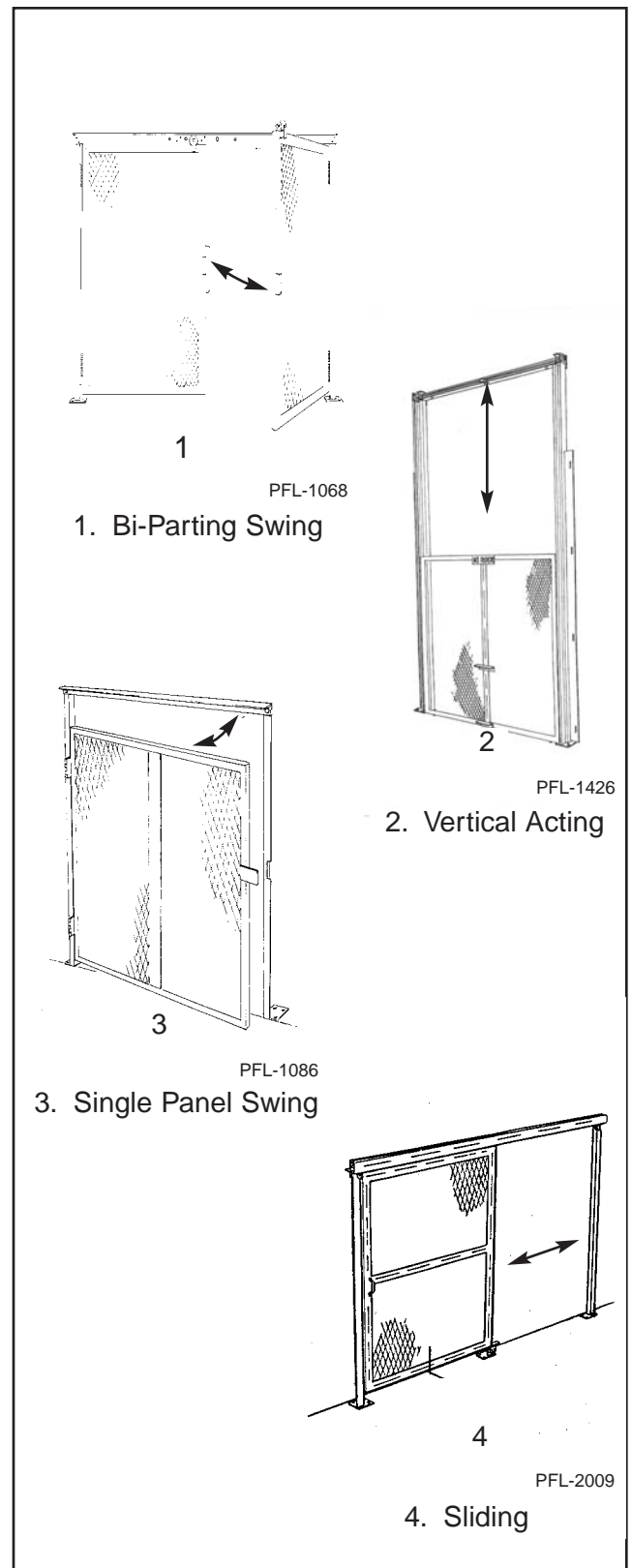

**Figure 8**

# 21 Series

Pflow Industries uses various styles of interlocks depending upon the gate type and application. The Parts section of this manual contains views with part numbers. See Figure 9.

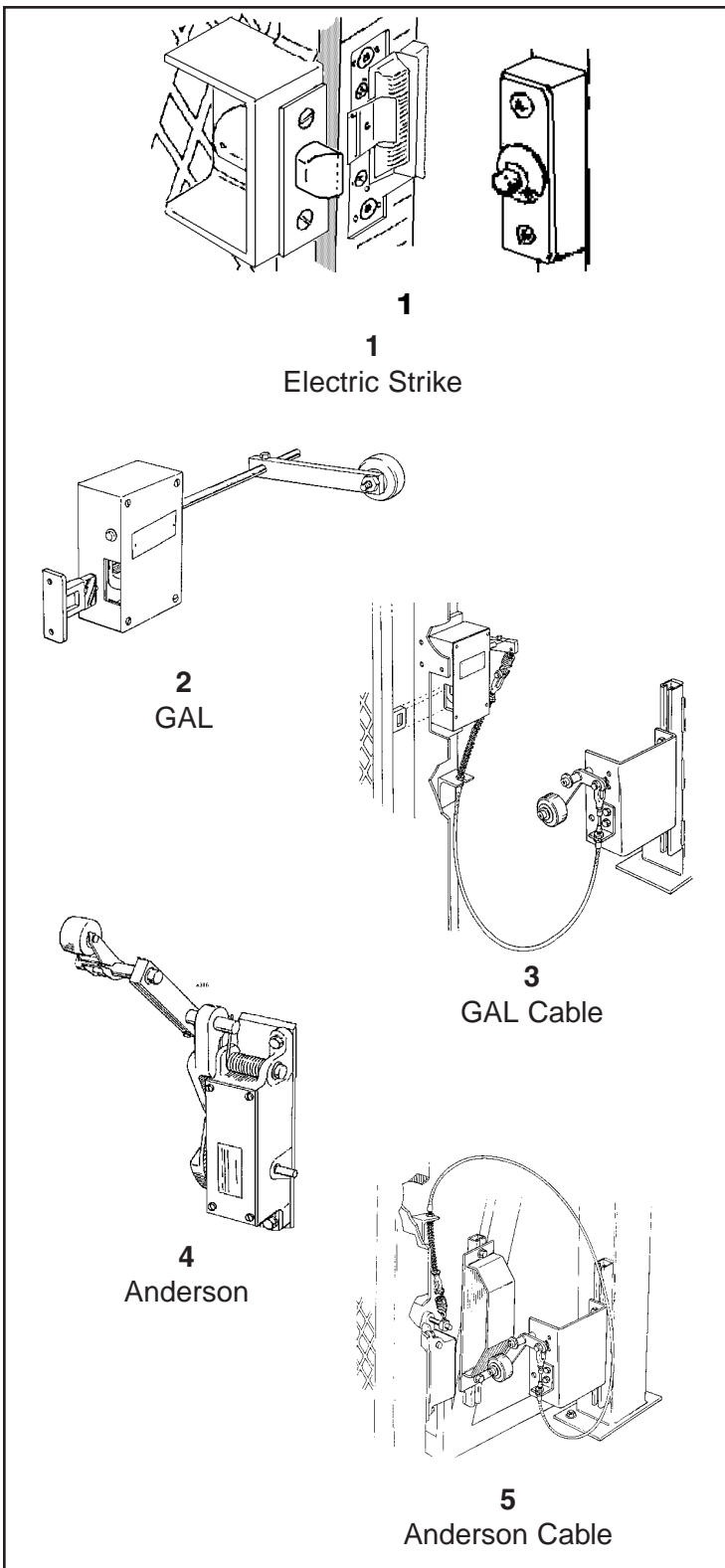

Figure 9

# Electrical Overview Series 21 - Without DeckLocks

## ELECTRICAL OVERVIEW

### NOTE

The following is a standard description of the electrical wiring of the VRC ONLY. It DOES NOT include specifics on options available or ordered. A copy of the schematic can be found in a manila envelope in the parts crate.

All electrical devices are tied into the **MAIN CONTROL PANEL**. It contains a fused transformer, which reduces the high voltage needed for the motor down to the voltage required to operate the control circuit, motor starter and push button stations. Overload heaters are provided to protect the motor should excessive current draw cause overheating. The fixed timing relay is used to time the solenoid to lower the lift to the first level. See Figure 10.

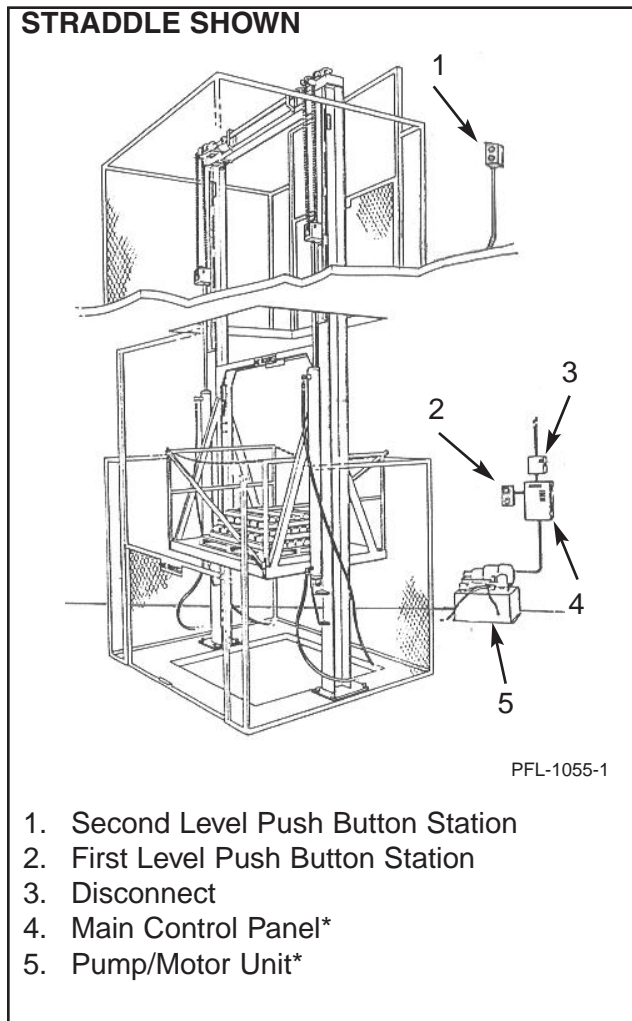

Figure 10

**PUSH BUTTON STATIONS.** One station is normally supplied for each level. ANSI/ASME B20.1 code requires that they be remotely located so they cannot be activated by someone standing on the carriage. Each station has an UP, DOWN, and EMERGENCY STOP button.

The UP and DOWN switches are momentary contact. This allows the operator to depress the button and let go. The EMERGENCY STOP button is pushed to activate but will stay in and must be pulled back out for the unit to operate.

Required by NEC code, the **MAIN DISCONNECT** should be fused, lockable, and located within line of sight of the control panel. (Not supplied by Pflow.)

The **MOTOR/PUMP** unit has two electrical components: a motor and an electrically actuated solenoid valve. We recommend the pump/motor unit be located within 6' of the unit.

### ⚠ WARNING

All gates or doors accessing the lift area must be electro-mechanically **INTERLOCKED**. This requires electrical contacts to prevent the lift from operating if a gate is open when the carriage is at that level and mechanical locks to lock the gate until the carriage is at that landing.

Different types and styles of interlocks are supplied depending upon the type of gate and on-site conditions. Standard styles incorporate from one to four electrical components per gate.

### \*NOTE

On Pflow's standard product line, the control panel is mounted to the motor/ pump unit stand.

# Series 21

## OPERATION

BEFORE OPERATING THE LIFT, PLEASE READ, UNDERSTAND AND FOLLOW ALL THE SAFETY PRECAUTIONS LISTED BELOW.

### **⚠ DANGER**

Malfunctioning interlocks may allow the door to be opened when the carriage is not present. **YOU MUST MAKE SURE CARRIAGE IS PRESENT BEFORE WALKING THROUGH DOORWAY.** If the carriage is not present, you could fall into the empty shaftway and be seriously injured or die!

### **⚠ DANGER**

Door must be closed and locked unless carriage is present. Door interlock must be operational. It prevents door from being opened when carriage is not present. Door restricts personnel from falling into opening or from being struck by moving parts that could result in serious injury or death!

### **⚠ DANGER**

DO NOT ride this equipment. Riding may result in serious injury or death! VRCs ARE NOT ELEVATORS.

### **⚠ DANGER**

DO NOT walk or work under a raised platform.

### **⚠ WARNING**

Only trained persons shall be permitted to operate or maintain this equipment. Improper operation or maintenance may cause serious injury or death!

### **⚠ WARNING**

If at any time proper operation or performance of your Pflow VRC is in question, DO NOT USE IT! Notify your supervisor or the proper maintenance people immediately.

### **⚠ WARNING**

Always return the carriage to the lowest level when the VRC is not in use.

### **CAUTION**

DO NOT allow loads to overhang the sides of the carriage. This will result in damage to the equipment and merchandise.

### **CAUTION**

DO NOT exceed the rated capacity.

### **TO OPERATE LIFT**

- Close gate.
- Depress and release the appropriate push button to move the carriage to the desired floor. The carriage will stop when it reaches the appropriate level.
- When the unit has arrived at the appropriate level and comes to a complete stop, open the gate.
- If an emergency occurs when the carriage is moving, push the EMERGENCY STOP button. The button will keep the lift inoperative until the button is pulled back out. See Figure 14.

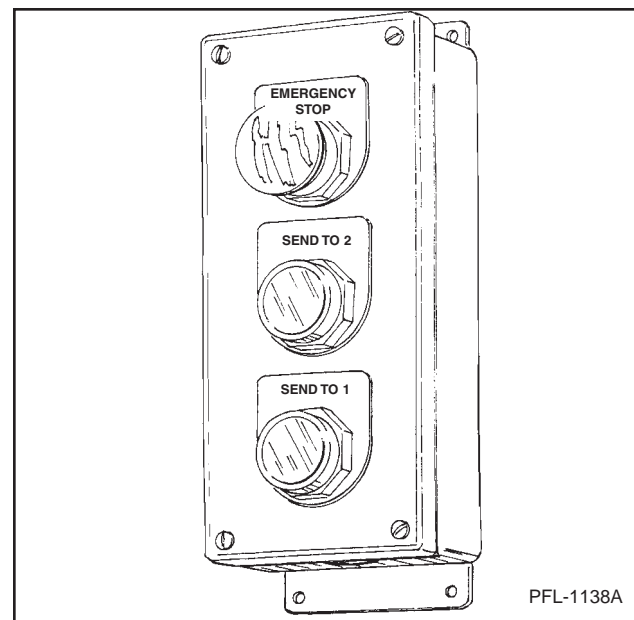

Figure 14

### **NOTE**

Service must be performed by authorized personnel only. Read the Owner's Manual before operating the equipment. For service, contact your local representative.

## SERVICE

### Maintenance of Pump Unit

#### NOTE

*The life of the hydraulic components is directly proportional to system cleanliness. If the oil is kept clean, is in good chemical condition, and its viscosity meets the operating temperature range, it will increase unit life.*

#### MAINTENANCE CHECK

1. Reservoir - Check the fluid level and make sure it is up to the full mark.
2. Inlet Line - Check for frays and kinks. Make sure the connections are secure and leak-proof.
3. Oil Viscosity - Do not use fluid that is too thick. Heat, high pressure, and contamination all speed up oxidation which results in gum, sludge, plugged valves, and excessive wear on the components.
4. Fluid - If it is cloudy, off-color, contains suspended sediment, or liquid layers, then changing the fluid is recommended.
5. Check and/or change the oil filter. Ten microns or less is recommended.

#### FILLING THE RESERVOIR

#### NOTE

*Hydraulic oil with a Saybolt viscosity of between 100 and 150 SSU or ISO 32 at operating temperatures with a non-foaming additive should be used.*

*Extreme temperatures below 32°F or above 100°F and corrosive atmosphere may affect oil requirements. Consult Pflow Industries for assistance.*

1. Wipe off the fill plug and the filler nozzle with a clean, lint-free cloth.
2. Watch for metallic chips, bits of waste, and other contaminants that may cause damage to the system.

3. Use a ten micron filter on the filler nozzle when adding oil.
4. The reservoir should be tightly closed after filling the system.

#### CLEANING THE RESERVOIR

#### NOTE

*The reservoir is a settling basin for any contamination. It is important to remove all accumulated sediment from the bottom. Wipe down the interior to remove any further impurities. The inside cover of the reservoir should also be checked. Large reservoirs can be a source of rust contamination due to condensation. The vibration of the pump unit results in the rust flaking off into the fluid.*

#### Maintenance Schedule

Your VRC requires consistent minimal and basic periodic attention. It is recommended that you keep a record during inspection and make a periodic evaluation of lubricating needs to reflect any increase in service that may be required. Problems must be addressed immediately as they may affect the safety devices.

#### NOTE

*Observe cycle day's schedule based on whichever comes first. High usage and corrosive environments will require more frequent maintenance and possibly different lubricants. (Check with your lubrication supplier for your particular needs.) Additional options, as ordered by the customer, may require maintenance and are not included in this information.*

If you have any questions or problems, please feel free to contact either your local service representative or our Product Support Department for assistance.

# 21 Series

INSPECT	NO. OF CYCLES/DAYS	ITEM	ACTION	REFERENCE
	1000/90	Bolts	Check for any loose bolts and tighten	Parts
	1000/90	Chains	Inspect for wear and alignment	Parts
	2000/90	Cylinder Fittings/ Hoses	Inspect for leaks	Parts
	2000/90	Wheelblock Wheels	Inspect for wear	Parts
	2000/90	Guide Rollers	Inspect for wear and rotation interference	Parts
	2000/90 6000/360	Hydraulic Oil Filter	Change after first 1000/30 then 6000/360 thereafter	Parts
	1 year	Reservoir	Drain and clean tank; Change oil and filter	Flushing Hydraulic System
	1000/90	Gates/Interlocks	Inspect for proper operation	
	1000/90	Sprockets	Inspect for wear and tighten set screws to 350 in/lbs.	
	1000/90	LevelDeck Bearings	Inspect for wear	

## Manual Release Valve

### CAUTION

#### For Emergency Use Only!

The down solenoid, also referred to as a dump valve, is equipped with a manual release valve. See Figure 15. This is to be used only in emergency situations when a load is stuck in upward mid-travel and the only way to free the load is to bring the unit down.

### WARNING

**Make sure that NO ONE is present in the enclosed area beneath the lift when operating this valve.**

1. To open or operate the manual release valve, turn it counterclockwise. This will allow the unit to descend.

2. Once the platform has reached the floor, turn the valve clockwise and close snugly.

If you have any questions or problems, please feel free to contact either your local service representative or our Product Support Department for assistance.

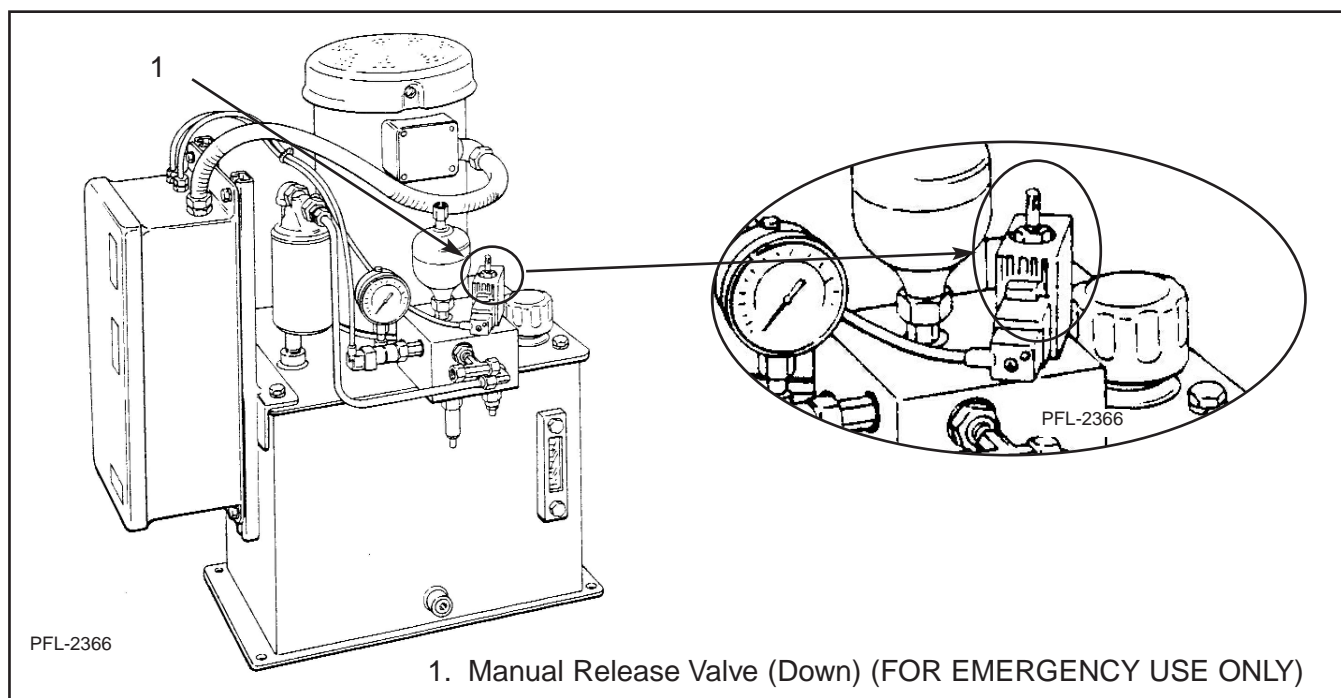

**Figure 15**

## Flushing Hydraulic System

### NOTE

*For prolonged service life, contamination must be periodically removed from hydraulic systems. Taking steps during the installation and daily operations to prevent contaminants from entering the system will help to prevent component failure and system down time.*

If contamination is evident in fluid samples, there is a good chance that accumulation has occurred somewhere within the system "plumbing." These deposits interfere with the operation of the unit and must be flushed with a light viscosity oil containing a rust inhibitor to protect the metal surfaces from rust formation after the hot flushing oil has been drained out.

1. Lower the carriage to the floor. Make sure the cylinders are fully extended.
2. Turn off power and lock out the disconnect.
3. Drain the system by removing plug near bottom of reservoir. See Figure 16. When draining the system, it is desirable to remove ALL of the used oil. Allow sufficient time for thorough draining so that a minimum of the old oil remains in the system. In most cases, bleeding at the lowest point in the system will help. It is also advisable to drain only after the oil is

fully warmed up (about 150°F). By doing this, oil impurities do not have a chance to settle and can be removed with the drained oil. The fluid should then be drained while it is hot.

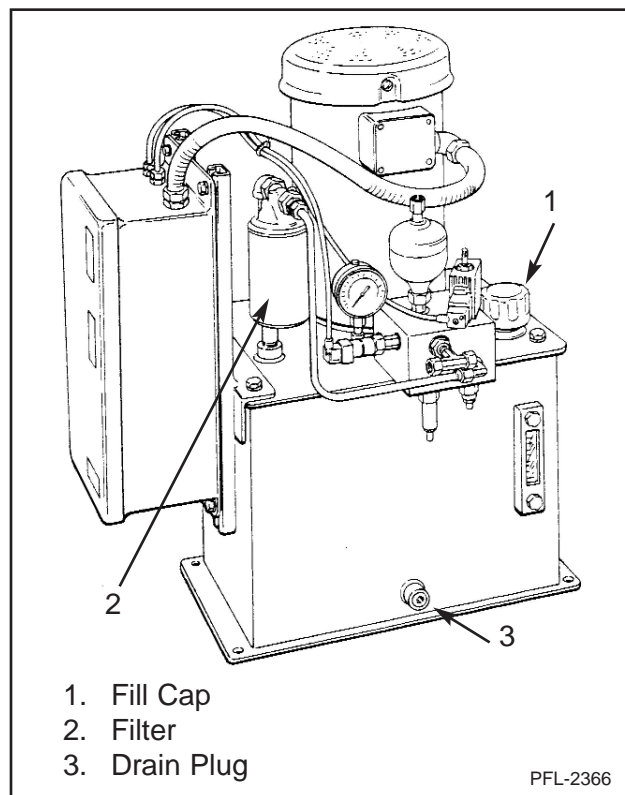

**Figure 16**

## 21 Series

---

4. Clean out the reservoir.
5. Refill the unit with oil. Before removing the filler cap to add oil to the hydraulic system, wipe off the fill plug and the filler nozzle with a clean, lint-free cloth. The safest way to pour oil from a container into a reservoir is to use a 10-micron filter on the filler nozzle. It is especially important to watch for metallic chips, bits of waste and other contaminants that may cause damage to the hydraulic system. The reservoir should be tightly closed after filling the system.
6. Remove lock and restore power.
7. Flush system. This is done by circulating a small percentage of special petroleum solvent cleaner with the fluid charge long enough to loosen and remove the deposits (10 to 50 hours depending on the condition). A careful watch on the filters will indicate when the system is clean.

### NOTE

*Hydraulic oil with a Saybolt viscosity of 150 SSU or ISO 32 at operating temperatures with a non-foaming additive should be used.*

- Solvents - Fluid suppliers are the best source for solvents. Solvents such as alcohol, kerosene, and carbon tetrachloride are low in viscosity and tend to: a) reduce the viscosity of the new fluid, b) may not hold the washed out contaminants in suspension and may deposit them in another part of the system.
8. Repeat steps 1 to 5.
  9. Replace the oil filter.
  10. Take all necessary steps to put the unit back into operation.

If you have any questions or problems, contact our Product Support Department for further assistance.

## SAFETY CAM INSPECTION

Routine inspection of the safety cams is extremely important as it is one of the major safety devices of our product.

### Visual

The cam should be checked for visual signs of wear. These include, but are not limited to, wear signs on the sides and chips in the teeth.

### Rotation

Rotation is important because it checks the actual operation of the cam.

1. Lower the carriage to the bottom level.
2. Shut off power at the main disconnect.
3. Open the manual release valve. (See Manual Release Valve, Page 16.) If your unit does not have a manual release valve, please contact Pflow Industries for further assistance.
4. Step onto the carriage. Slacken the cable or chain on each cylinder. Pull enough cable or chain to allow the safety cams to engage. Usually one to two feet is sufficient. (This will take considerable force as you are also extending the cylinders.) Check to see that the safety cams rotate freely and they are touching the column without obstructions.
5. Close the manual release valve. Reassemble the caution label with the nut.
6. Check to make sure that the cables or chains are properly aligned on all sprockets and sheaves.
7. Turn main disconnect back on.
8. Cycle lift several times to check for proper operation.

If you have any questions or concerns during the course of the inspection, please feel free to contact the Product Support Department.

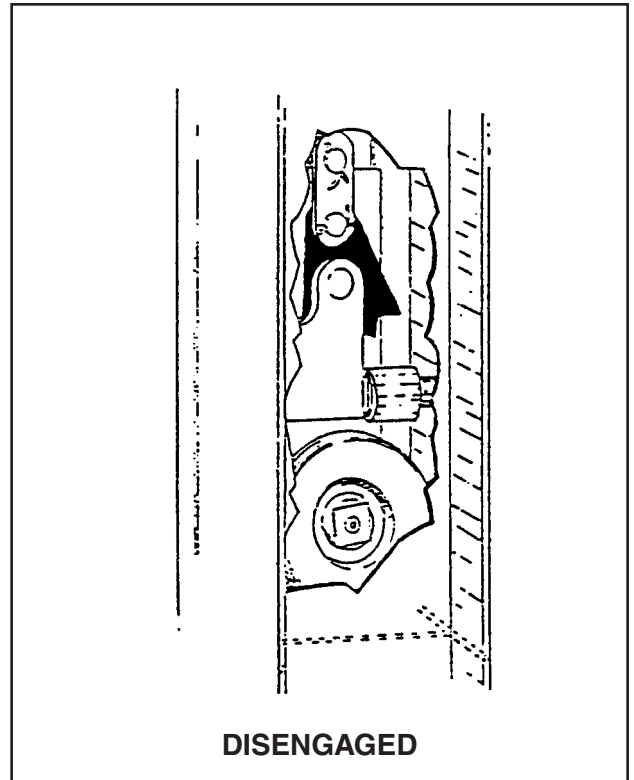

**DISENGAGED**

**Figure 17**

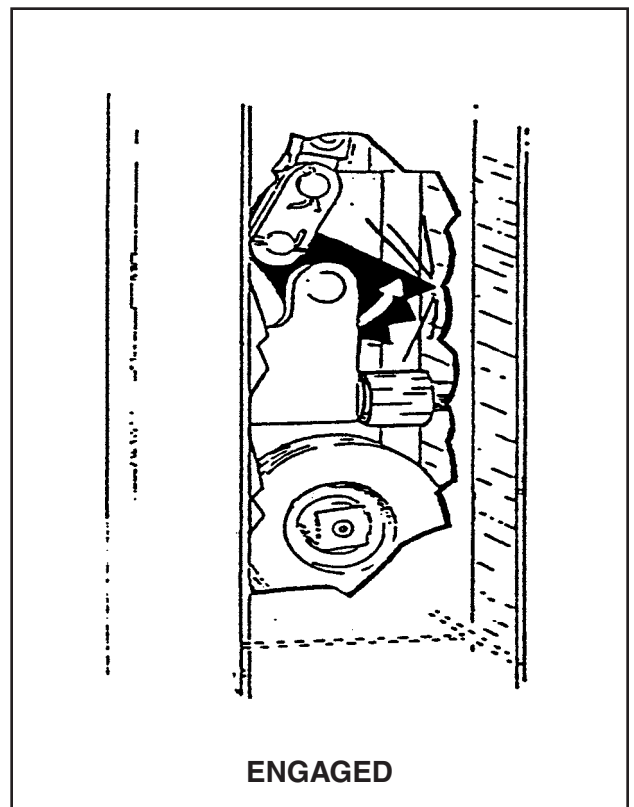

**ENGAGED**

**Figure 18**

# 21 Series

## TROUBLESHOOTING

Before troubleshooting, please observe all of the precautions in the Safety section at the front of this manual.

The following is a list of common problems and solutions:

SYMPTOM	POSSIBLE CAUSE	SUGGESTED SOLUTION	REF.
Lift doesn't operate when controls (push buttons) are activated.	Gate or door is open or ajar.	Check all gates/doors to make sure they are closed.	Mechanical Overview
	Main disconnect is off.	Check to see if there is a reason before turning on.	
	Thermal overload has tripped.	Press reset button. If it trips again, determine cause. Motor is overheating.	
	Control fuse is blown.	Replace fuse after determining cause.	
	Power circuit between disconnect and starter is dead.	Use a voltmeter to check voltage. Repair as needed.	
Motor starts and carriage raises, but motor stops before second level.	Safety gate has been opened.	Close gate. Check to see why this has happened.	Mechanical Overview
	Object encountered.	Identify the problem. Remove or repair as needed.	
	Piston (cylinder) interference.	Remove object. Repair if needed.	
	Thermal overload has tripped.	Check for pump binding.	
	Carriage is overloaded.	Lower, and remove excess weight.	Parts
Motor/pump runs but carriage does not raise, and there is no pressure shown on gauge.	Oil in reservoir is less than 3/4 full.	Add oil to proper level.	Maintenance and Troubleshooting of Pump Unit
	Motor rotation is incorrect.	Contact your electrician.	
	Relief valve setting is too low.	Increase spring pressure by turning stem clockwise a few times. DO NOT OVER or FULLY TIGHTEN. Damage will result. A few turns should show pressure on the gauge.	
	Pump cavitating.	Oil supply is low. Fill reservoir. Oil is too heavy. Change to proper viscosity oil.	
	Accumulator is plugged.	Open reservoir; inspect pickup tube, clean if required.	
Pump is not working or turning.	Motor/pump coupling broken. Pump impeller not turning.	Call Pflow Industries.	

# Troubleshooting

SYMPTOM	POSSIBLE CAUSE	SUGGESTED SOLUTION	REF.
Motor/pump runs, but carriage does not raise, and there is erratic or low pressure shown on gauge.	Oil is foaming	Air is leaking into suction line because of loose fittings. Check all fittings. Water or incompatible oils causing foaming. Drain and replace with proper type oil.	Maintenance and Troubleshooting of Pump Unit
	Low oil level.	Add to proper level.	
Carriage raises but will not lower.	Mechanical interference.	Identify the problem. Remove and repair as needed.	Parts-Hydraulic Layout
	Dump valve not actuating.	Depress the DOWN button and listen carefully. If it does not click, it is not operating. Then proceed with: 1. Using a voltmeter, determine that the solenoid is receiving current when the button is pressed. If it is not, check the operation of the timing relay and then the motor starter (contacts in the control circuit). 2. If the solenoid is receiving current, check the end of the solenoid coil with a screwdriver. When energized, there will be a magnetic pull. If no magnetic pull is present, replace the solenoid.	
	Velocity fuse triggered.	Check for hose break or fitting leak. If none found, attempt to increase pressure in cylinders by pressing UP button.	
Motor/pump keeps running after pressure reaches the relief valve setting	Relief valve set too low.	Readjust relief valve. Consult Product Support Department for instructions.	Parts
	Bad pressure relief valve.	Replace relief valve.	
	Upper limit switch is not activating.	Check for possible adjustment.	
Pump stops suddenly.	Major internal pump has failed.	Examine the pump and rebuild or replace as necessary.	Maintenance and Troubleshooting of Pump Unit.
Carriage drifts down from raised position. (NOTE: 3-4 inches overnight is normal.)	Internal leakage.	Contamination is keeping the dump valve from seating. Remove solenoid coil and valve spool. Clean spool and seat with the recommended solvent or cleaner. Dry with a lint-free cloth. Replace coil and spool. Test. Inspect oil in reservoir.	Maintenance and Troubleshooting of Pump Unit.
		Oil is bypassing the piston seals. Remove and clean seals. If worn, replace. Inspect breather for leakage.	

## 21 Series

SYMPTOM	POSSIBLE CAUSE	SUGGESTED SOLUTION	REF.
Carriage lowers but stops early.	Debris in the pit.	Clean out pit.	Maintenance and Troubleshooting of Pump Unit
	Dump valve not working properly.	See "Carriage raises but it will not lower" for instructions.	
	Faulty timer	Replace.	
Rough or noisy operation.	Travel interference.	Identify. Remove or repair as needed.	Parts
	Drive component interference.	Identify. Remove or repair as needed.	
	Wheel guide rollers worn.	Inspect, lubricate, and replace as needed. Determine why they wore out.	
	Carriage is not level.	Determine cause and correct.	
Carriage binding.	Cylinders operating out of sequence. Seal bad in one cylinder.	Inspect cylinders and hoses.	
Carriage is spongy or bouncy.	Air in cylinders.	Run unit numerous times to remove air. Bleed cylinders. If you do not know how to do this, contact the Product Support Department, Pflow Industries.	Maintenance and Troubleshooting of Pump Unit
	Binding	Check mechanical and hydraulic components.	
Excessive temperature and pump noise.	Defective, damaged or worn pump.	Contact Product Support Department, Pflow Industries.	
	Cavitation*	Add hydraulic fluid to reservoir.	
	Aeration**	Air is leaking into suction line because of loose fittings. Check all fittings.	

### NOTE

\* **Cavitation** is a vacuum in the fluid caused by a restricted or sharp bend in the inlet line, a clogged filter, or by fluid that is too high in viscosity. The characteristic sound of cavitation is a high-pitched "scream." The noise increases with the degree of cavitation and with increased operating pressure.

\*\* **Aeration** is the presence of excessive air, usually in the form of bubbles, disbursed through the fluid caused by a damaged inlet or return line; a loose or defective fitting(s) or seal(s); damaged or worn cylinder rod, packing, or seals; cracked junction blocks, tees, or piping; fluid level too low; air trapped in filter or excessive air trapped after adding fluid. Overheating or jerky and uneven movement in the pump or cylinders are the obvious symptoms of aeration.

If you need further assistance, please call the Product Support Department of PFLOW INDUSTRIES, INC.; (414) 462-8810.

**PARTS**  
**Motor Pump and Motor Assembly**

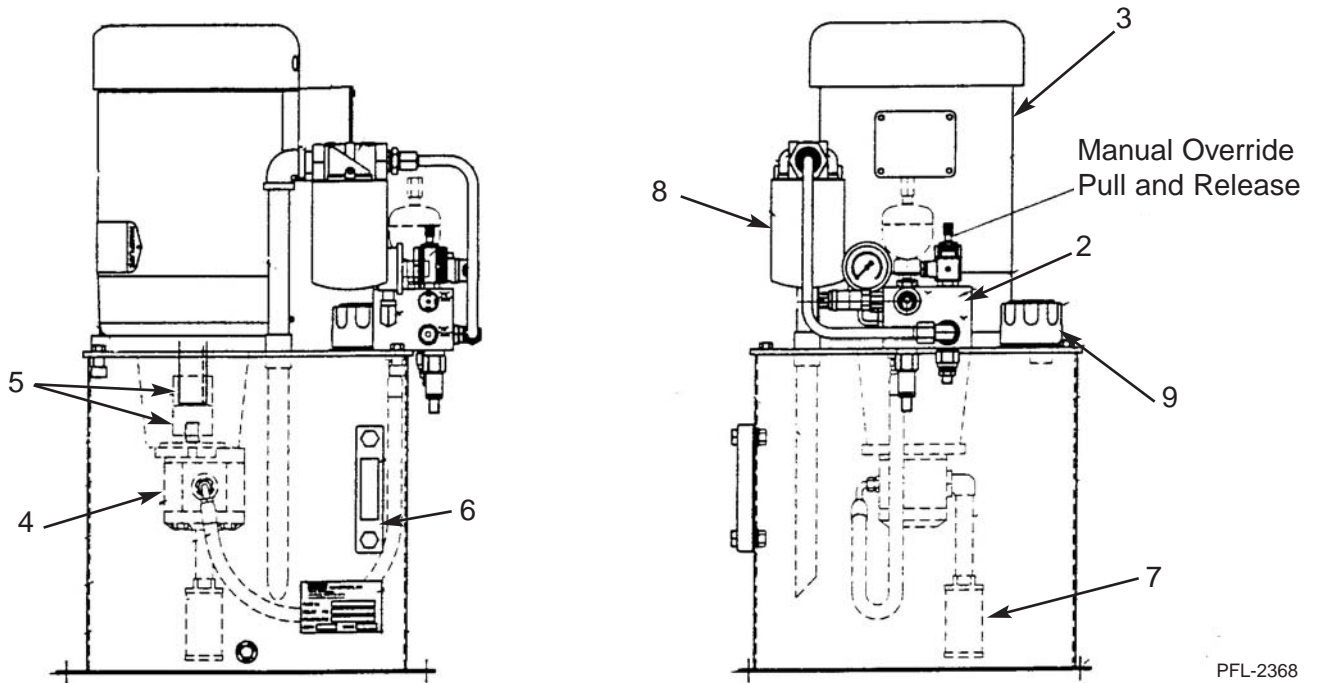

Item	Qty.	Part No.	Description
1	1	Contact Factory	Hydraulic Pump and Motor Assembly
2	1	11078-0016	Manifold Block Assembly
3	1	Contact Factory	Motor Assembly, Pump
4	1	Contact Factory	Pump Assembly, Hydraulic
5	1	11078-0020	Coupling, Motor Half
		11078-0021	Coupling, Pump Half
		11078-0022	Insert, Coupling
6	1	11078-0013	Gauge, Oil Sight
7	1	11078-0012	Strainer, Hydraulic Oil
8	1	11078-0011	Filter, Hydraulic Oil
9	1	11078-0007	Breather, Oil Fill

# 21 Series

## Parts Manifold Block Assembly

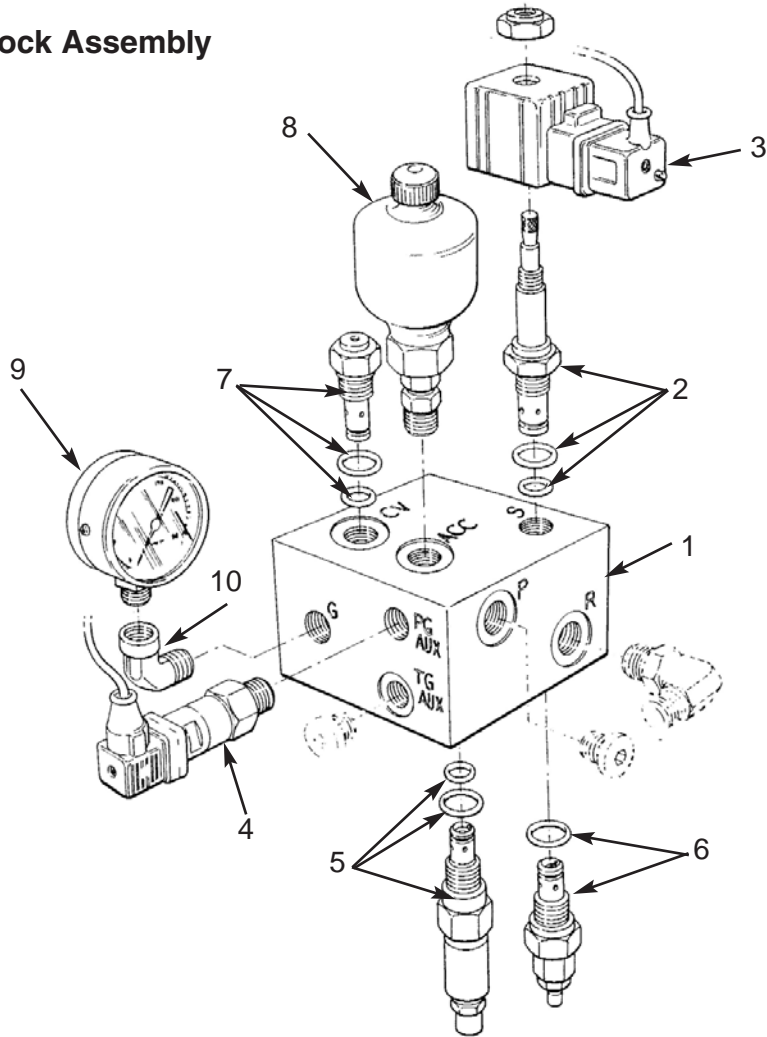

PFL-2372-1

Item	Qty.	Part No.	Description
1	1	11078-0016	Manifold Block Assembly
2	1	11078-0002	Valve, Down with Manual Release
3	1	11078-0005	Coil, Down Valve - 24 V
4	1	11078-0006	Switch, Pressure
5	1	11078-0004	Valve, Relief
6	1	11078-0001	Valve, Flow Control
7	1	11078-0003	Valve, Check
8	1	11078-0014	Accumulator (Optional)
9	1	11078-0015	Gauge, Pressure (Optional)
10	1	Local Item	Elbow, 1/4" NPT Street

Adjustable Wheelblock Assembly

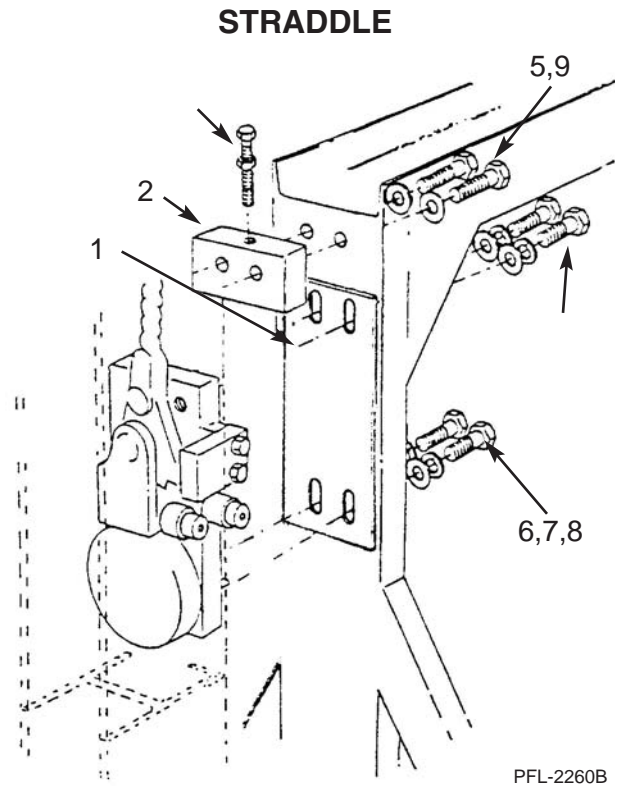
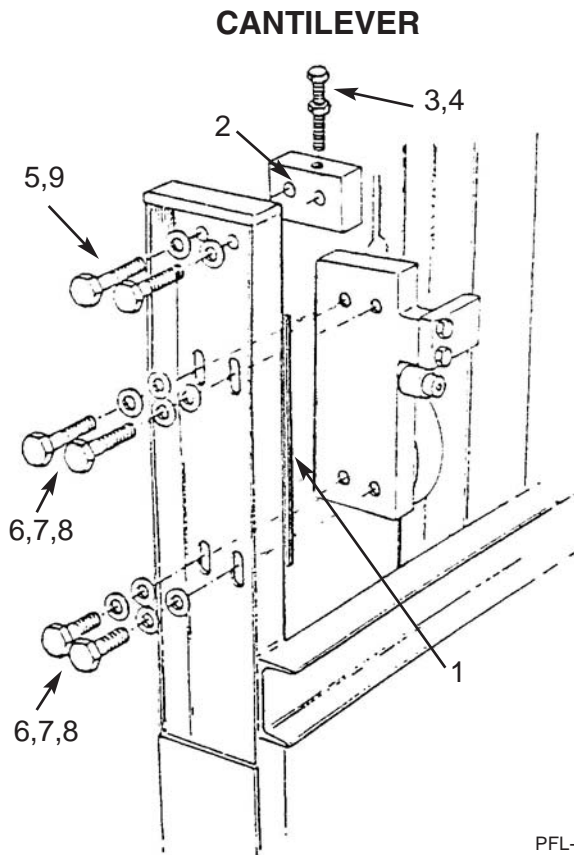

Item	Qty.	Part No.	Description
1	1	2377-0001	Spacer (welded to carriage), Wheelblock, 1/8" (Not used on 4" upright)
2	1	9677-0000	Block, Adjuster
3	1	8872-0088	Screw, HHC, 1/2-13, UNC 5-1/2
4	1	6358-0013	Nut, Hex, 1/2-13
5	2	9237-0020	Screw, HHCS, 1/2-13
6	4	5858-0015	Lockwasher, STD 5/8
7	4	6296-0015	Washer, Flat, 5/8
8	4	6758-0020	Screw, 5/8-11 UNC x 1 1/4
9	2	5858-0013	Lockwasher, STD 1/2

# 21 Series

## Upper Wheelblock Assembly - Phenolic

Complete Assembly (5-1/4) - Part No. 6196-0000 / Part No. 6197-0000

Complete Assembly (5-3/8) - Part No. 6196-1000 / Part No. 6197-1000

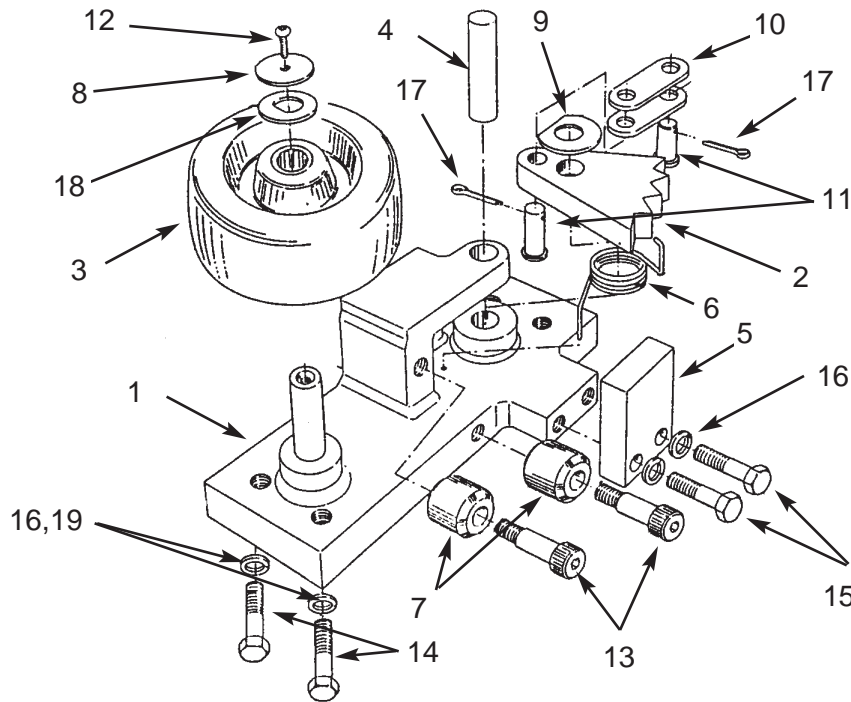

PFL-1605

Item	Qty.	Part No.	Description
1	1	Consult Factory	Wheelblock Weldment, RH or LH
2	1	6186-0000	Cam, Safety
3	1	2591-0000	Wheel, Phenolic (5-1/4)
	1	2591-1001	Wheel, Phenolic (5-3/8)
4	1	5230-0000	Pin, Cam
5	1	2754-0000	Shoe
6	1	2443-0000	Spring, Cam, RH, or
	1	2127-0000	Spring, Cam, LH
7	2	5221-0000	Roller, Guide
8	1	5222-0000	Washer, Flat 9/32 ID x 1-1/2 OD
9	1	8339-0000	Bearing Thrust
10	2	6187-0000	Link, Safety Cam to Toggle
11	2	2521-0000	Pin, Clevis 3/4 x 2
12	1	2888-0010	Screw, BHC, 1/4-20 x 5/8
13	2	5874-0020	Bolt, Shoulder, 5/8 x 1-1/4
14	4	6758-0020	Screw, HHC, 5/8-1 x 1-1/4
15	2	2198-0040	Screw, HHC, 5/8-11 x 2-1/4, Grade 8
16	6	5858-0015	Lockwasher, STD 5/8
17	2	2522-0000	Pin, Cotter
18	1	8774-0000	Washer, D
19	4	7768-0015	Washer, Flat, 5/8 SAE

## Lower Wheelblock Assembly - Phenolic

Complete Assembly (5-1/4) - Part No. 2721-0000 / Part No. 2089-0000

Complete Assembly (5-3/8) - Part No. 2721-1000 / Part No. 2089-1000

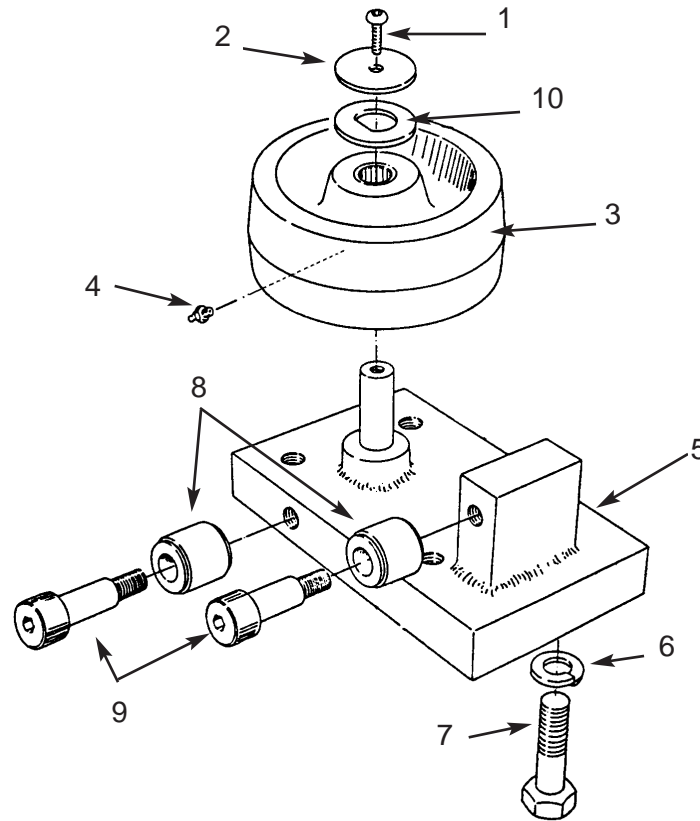

PFL-1606

Item	Qty.	Part No.	Description
1	1	2888-0010	Screw, BHC, 1/4-20 x 5/8
2	1	5222-0000	Washer, Flat
3	1	2591-0000	Wheel, Phenolic (5-1/4)
	1	2591-1001	Wheel, Phenolic (5-3/8)
4	1	2590-0000	Grease Fitting, Zerk
5	1	Consult Factory	Wheelblock Weldment, RH or LH
6	4	5858-0015	Lockwasher, STD 5/8
7	4	6758-0020	Screw, HHC, 5/87-11 x 1 1/4
8	2	5221-0000	Roller, Assembly
9	2	5874-0020	Bolt, Shoulder, SH, 5/8 x 1 1/4
10	1	8774-0000	Washer, D

# 21 Series

## Upper Wheelblock Assembly 5 1/4 Steel Wheel w/Roller Bearing

Complete Assembly - Part No. 6492-0000, Left Hand

Complete Assembly - Part No. 6491-0000, Right Hand

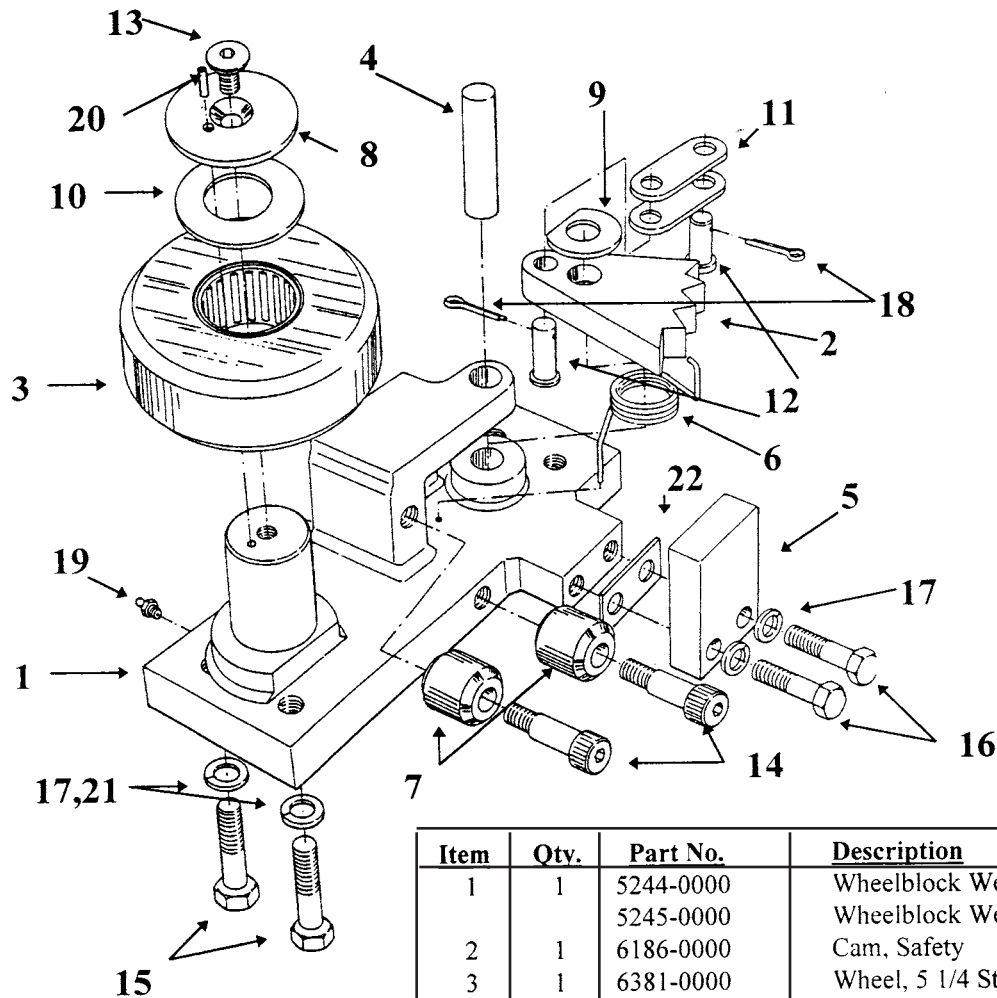

PFL-2100

\* number of spacers dependent  
on beam size: #15=0; #20=1;  
#25=2;

Item	Qty.	Part No.	Description
1	1	5244-0000 5245-0000	Wheelblock Weldment, RH, or Wheelblock Weldment, LH
2	1	6186-0000	Cam, Safety
3	1	6381-0000	Wheel, 5 1/4 Steel w/ Roller Bearing
4	1	5230-0000	Pin, Cam
5	1	2754-0000	Shoe
6	1	2443-0000 2127-0000	Spring, Cam, RH, or Spring, Cam, LH
7	2	5221-0000	Roller, Guide
8	1	3629-0000	Retainer, Steel Wheel
9	1	8339-0000	Bearing, Thrust
10	1	3622-0000	Washer, Thrust, 1 3/4 Whl Stud
11	2	6187-0000	Link, Safety Cam to Toggle
12	2	2521-0000	Pin, Clevis, 3/4 x 2
13	1	4299-0016	Screw, FHSC, 1/2-13 x 1
14	2	5874-0020	Bolt, Shoulder, 5/8 x 1 1/4
15	4	6758-0020	Screw, HHC, 5/8-1 x 1 1/4
16	2	2198-0040	Screw, HHC, 5/8-11 x 2 1/4, Grade 8
17	6	5858-0015	Lockwasher, STD 5/8
18	2	2522-0000	Pin, Cotter
19	1	2590-0000	Fitting, Zerk, 3/16 Drive Type
20	1	5209-0012	Pin, Roll
21	4	7768-0015	Washer, Flat, 5/8 SAE
22	*	2767-0000	Spacer, Wheelblock Shoe, .08 thick

**Lower Wheelblock Assembly**  
**5 1/4 Steel Wheel w/Roller Bearing**

Complete Assembly - Part No. 6493-0000, Right Hand

Complete Assembly - Part No. 6494-0000, Left Hand

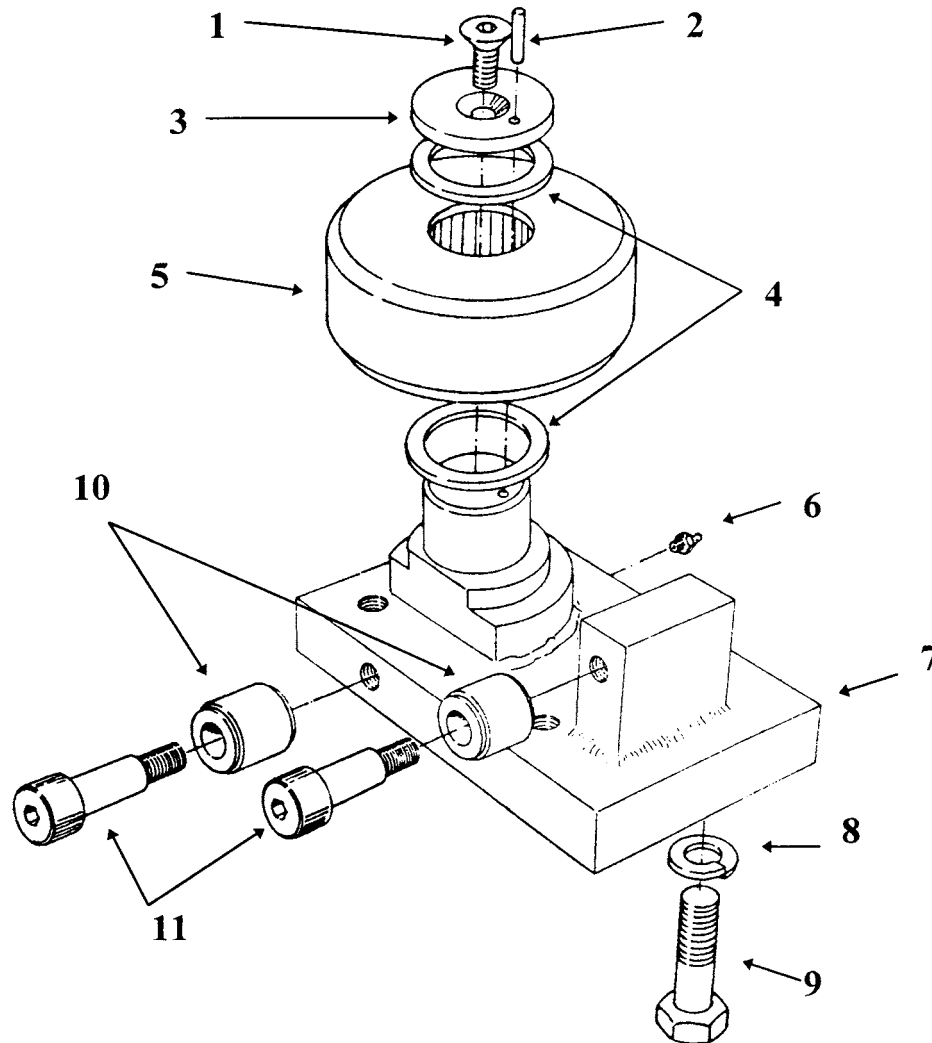

<u>Item</u>	<u>Qty.</u>	<u>Part No.</u>	<u>Description</u>
1	1	4299-0016	Screw, FHSC, 1/2 x 1 w/Nylock
2	1	5209-0012	Pin, Roll
3	1	3629-0000	Retainer, Steel Wheel
4	2	3622-0000	Washer, Thrust
5	1	6381-0000	Wheel, Steel, 5 1/4 w/Roller Bearing
6	1	2590-0000	Grease Fitting, Zerk
7	1	2400-0000	Weldment, Wheelblock, Lower RH
		2453-0000	Weldment, Wheelblock, Lower LH
8	4	5858-0015	Lockwasher, STD 5/8
9	4	6758-0020	Screw, HHC, 5/8-11 x 1 1/4
10	2	5221-0000	Roller Assembly.
11	2	5874-0020	Bolt, Shoulder, SH, 5/8 x 1 1/4 x 1/2-13

PFL-2101

# 21 Series

## Upper Wheelblock Assembly 5 3/8 Steel Wheel w/Roller Bearing

Complete Assembly - Part No. 6198-0000, Left Hand

Complete Assembly - Part No. 6199-0000, Right Hand

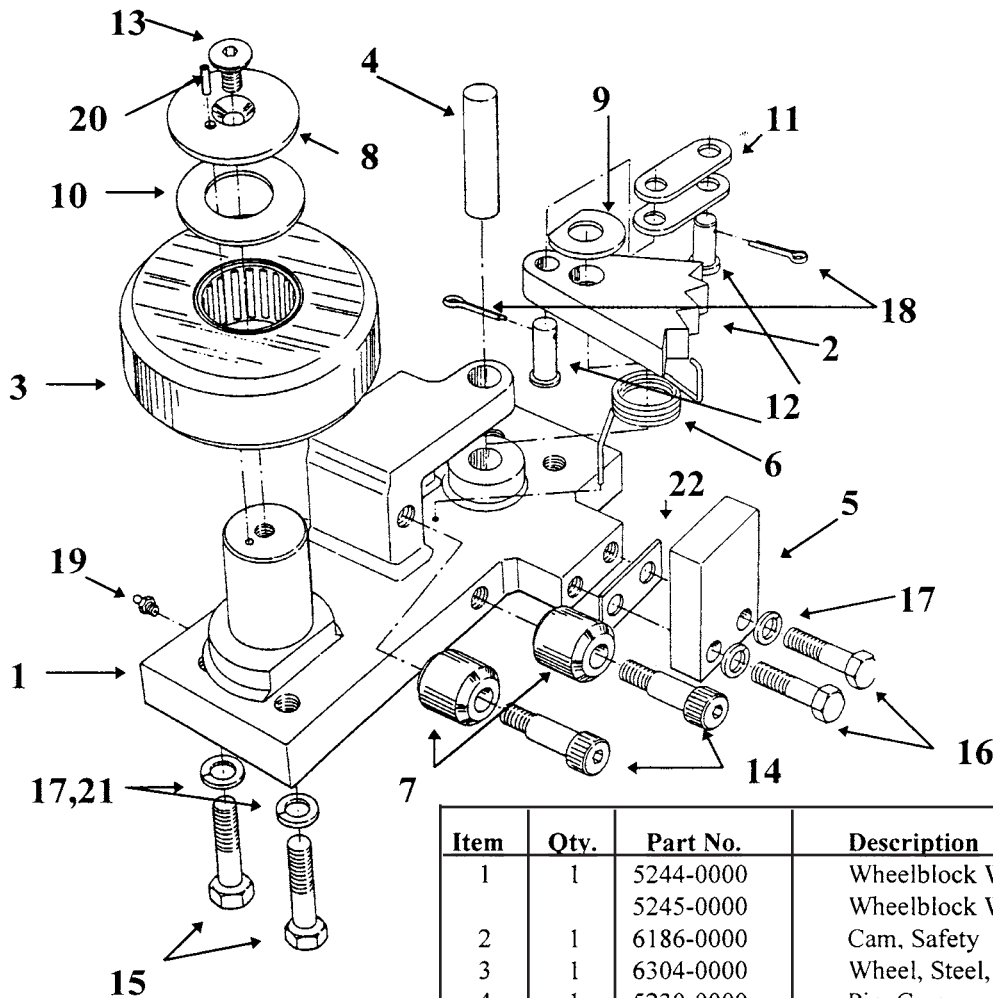

PFL-2104

\* Number of spacers dependent  
on beam size: #15 = 0; #20 = 1;  
#25 = 2.

Item	Qty.	Part No.	Description
1	1	5244-0000 5245-0000	Wheelblock Weldment, RH, or Wheelblock Weldment, LH
2	1	6186-0000	Cam. Safety
3	1	6304-0000	Wheel, Steel, 5 3/8 w/ Roller Bearing
4	1	5230-0000	Pin, Cam
5	1	2754-0000	Shoe
6	1	2443-0000 2127-0000	Spring, Cam, RH, or Spring, Cam, LH
7	2	5221-0000	Roller, Guide
8	1	3629-0000	Retainer, Steel Wheel
9	1	8339-0000	Bearing, Thrust
10	1	3622-0000	Washer, Thrust, Wheel Stud
11	2	6187-0000	Link, Safety Cam to Toggle
12	2	2521-0000	Pin, Clevis, 3/4 x 2
13	1	4299-0016	Screw, FHSC, 1/2-3 x 1
14	2	5874-0020	Bolt, Shoulder, 5/8 x 1 1/4
15	4	6758-0020	Screw, HHC, 5/8-1 x 1 1/4
16	2	2198-0040	Screw, HHC, 5/8-11 x 2 1/4, Grade 8
17	6	5858-0015	Lockwasher, STD 5/8
18	2	2522-0000	Pin, Cotter
19	1	2590-0000	Fitting, Zerk, 3/16 Drive Type
20	1	5209-0012	Pin, Roll
21	4	7768-0015	Washer, Flat, 5/8 SAE
22	*	2767-0000	Spacer, Wheelblock Shoe, .08 thick

**Lower Wheelblock Assembly**

**5 3/8 Steel Wheel w/Roller Bearing**

Complete Assembly - Part No. 2403-0000, Right Hand

Complete Assembly - Part No. 2474-0000, Left Hand

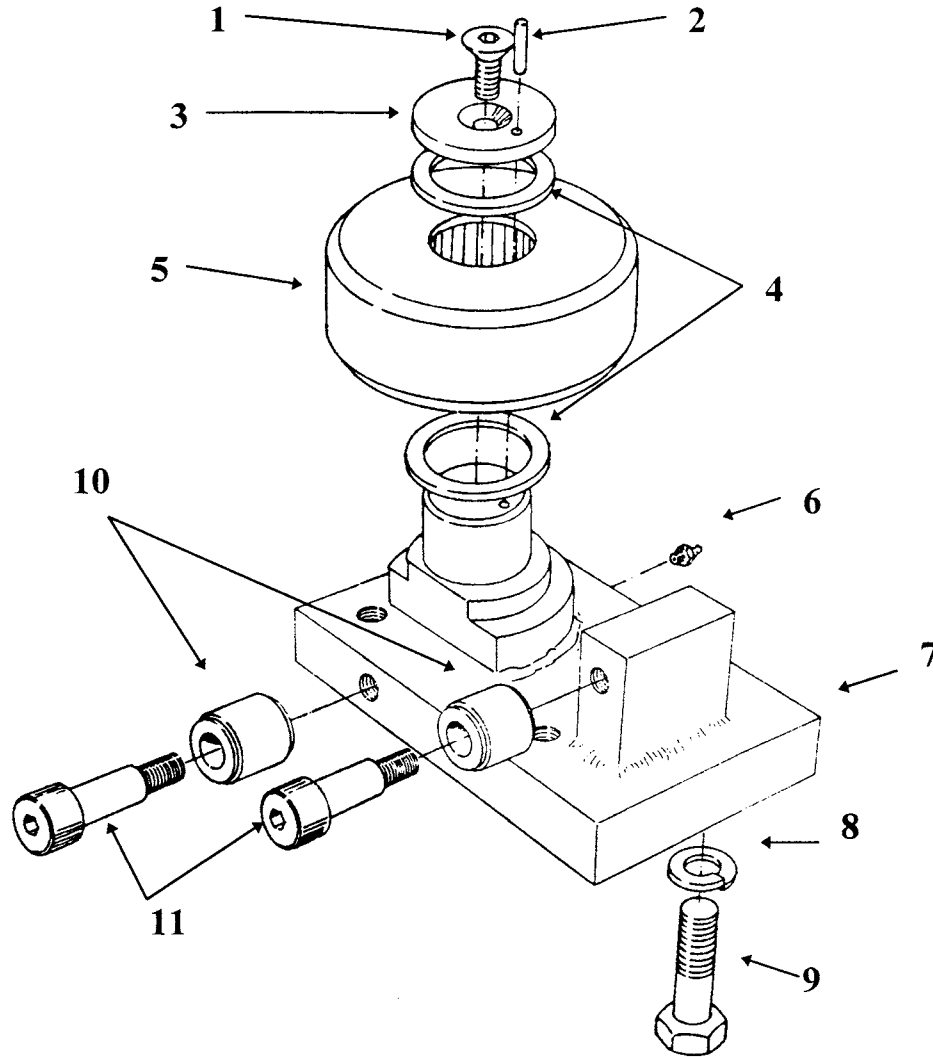

Item	Qty.	Part No.	Description
1	1	4299-0016	Screw, FHSC, 1/2 x 1 w/Nylock
2	1	5209-0012	Pin, Roll
3	1	3629-0000	Retainer, Steel Wheel
4	2	3622-0000	Washer, Thrust
5	1	6304-0000	Wheel, Steel, 5 3/8 w/Roller Bearing
6	1	2590-0000	Grease Fitting, Zerk
7	1	2400-0000	Weldment, Wheelblock, Lower RH
		2453-0000	Weldment, Wheelblock, Lower LH
8	4	5858-0015	Lockwasher, STD 5/8
9	4	6758-0020	Screw, HHC, 5/8-11 x 1 1/4
10	2	5221-0000	Roller Assembly
11	2	5874-0020	Bolt, Shoulder, SH, 5/8 x 1 1/4 x 1/2-13

PFL-2105

# 21 Series

## Clevis Assembly

Complete Assembly - Part No. 9380-0000, Right Hand, #80 Chain

Complete Assembly - Part No. 9380-0001, Left Hand, #80 Chain

Complete Assembly - Part No. 9381-0000, Right Hand, #100 Chain

Complete Assembly - Part No. 9381-0001, Left Hand, #100 Chain

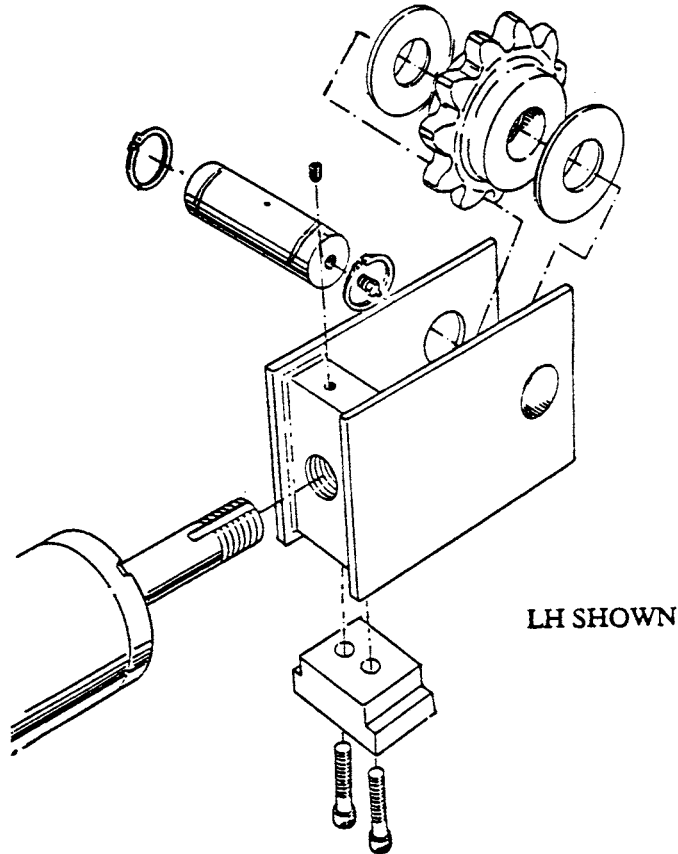

PFL-2108

ITEM	QTY.	PART NO.	DESCRIPTION
1	1	8761-0000	Slide Block, UHMW
2	2	3666-0024	Screw, SHC, 5/16-18 x 1 1/2" LG
3	1	9376-0000	Clevis Weldment, Right Hand
3	1	9376-0001	Clevis Weldment, Left Hand
4	1	9375-0000	Clevis Pin, 1 3/4" Dia.
5	2	8760-0000	Thrust Washer, UHMW
6*	1	8823-0000	Sprocket, #80 Chain
6*	1	8824-0000	Sprocket, #100 Chain
7	2	7993-0028	Snap Ring, 1 3/4" Dia.

\*Applicable to lift chain size.

## LevelDeck Shaft Assembly - Straddle

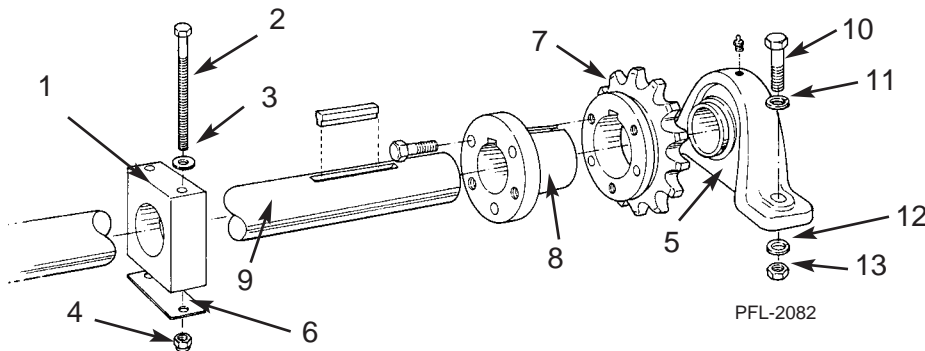

## LevelDeck Shaft Assembly - Cantilever

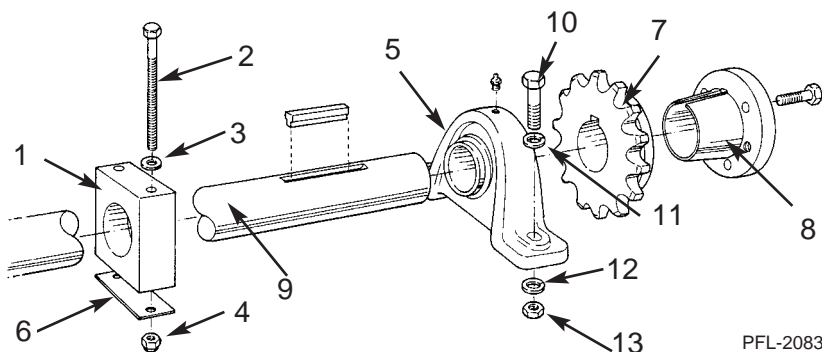

### CAUTION

- Confirm sprocket is aligned correctly in field.
- Verify the tapered surfaces of the sprocket and bushing are clean and dry.
- **DO NOT USE LUBRICANT ON THE CAPSCREWS.**
- Confirm all capscrews are tightened evenly and in rotation to 348 in-lbs.
- **DO NOT OVER TORQUE. DO NOT ATTEMPT TO CLOSE GAP BETWEEN BUSHING FLANGE AND SHEAVE HUB.**

Items	Qty.	Straddle Part No.	Cantilever Part No.	Description
1	1	9537-0000		Support Shaft, 2-3/16" Dia.
1	1		9541-0000	Support, Shaft, 2-3/8" Dia.
2	2	5927-0088	5927-0088	Screw, HHC, 3/8-16 UNC 5-1/2" LG
3	2	6296-0011	6296-0011	Washer, Flat, Std, 3/8"
4	2	6708-0011	6708-0011	Nut, Lock, Nylon, 3/8-16 UNC
5	2	9555-0000		Bearing, Pillow Block 2-3/16 Set Screw Type
5	2		5653-0000	Bearing, Pillow Block 2-3/8 Std. Duty Brg.
5	2		9520-0000*	Bearing, Pillow Block 2-3/8 Med. Duty Brg.
6	1+	9554-0000	9554-0000	Shim, Shaft Support, (2 Standard)
7	2	9546-0000		Sprocket, 80Q15
7	2	9548-0000	9548-0000	Sprocket, 100Q12
8	2	9547-0000		Bushing, Split Taper, Type 2, 2-3/16" Bore
8	2		9547-0001	Bushing, Split Taper, Type 2, 2-3/8" Bore
9	1	9560-1000		Shafting, 1144 G&P, 2-3/16 x "Shaft Length
9	1		9560-2001	Shafting, 1144 G&P, 2-3/8 x "Shaft Length
10	4	6758-0040	6758-0040	Screw, HHC, 5/8-11 x 2-1/2" LG
10	4		6772-0040	Screw, HHC, 3/4-10 x 2-1/2" LG
11	4	6296-0015	6296-0015	Washer, Flat, Std, 5/8"
11	4		6296-0017	Washer, Flat, 3/4"
12	4	5858-0015	5858-0015	Lockwasher, Std, 5/8"
12	4		5858-0017	Lockwasher, 3/4"
13	4	6358-0015	6358-0015	Nut, Hex, 5/8-11 UNC
13	4		6358-0016	Nut, Hex, 3/4-10 UNC

NOTE: \*1/4" additional shims required with medium bearing.

Items 8 and 9 are supplied as an assembly with a special key and screws.

# 21 Series

## Adjustable Carriage Stop

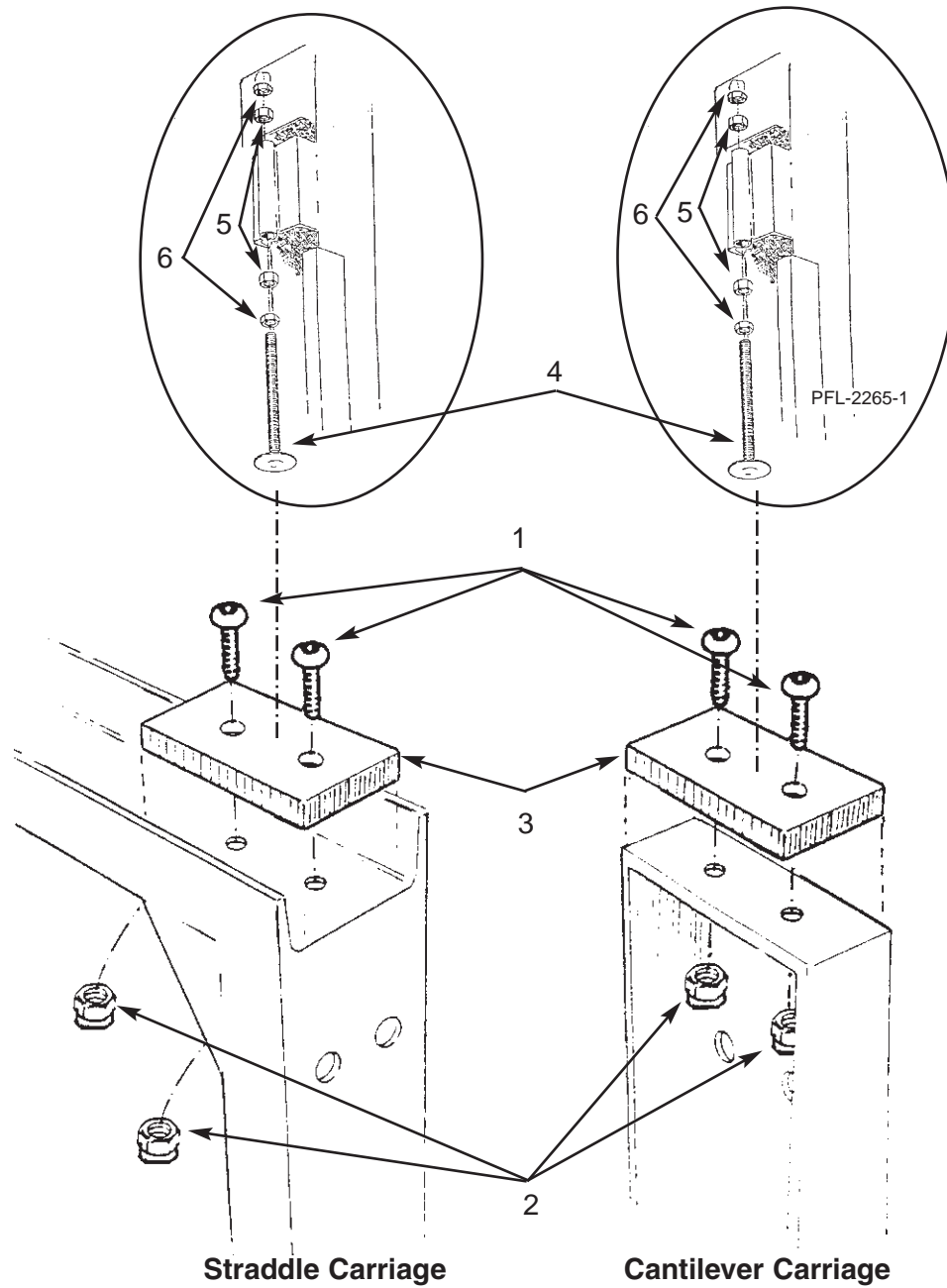

PFL-1301-1

Item	Qty.	Part No.	Description
1	1	8399-0016	Screw, BHSC 3/8-16 UNC 1"
2	2	6708-0011	Nut, Lock, Nylon, 3/8
3	1	10414-0000	Pad, UHMW
4	1	6140-0000	Jackscrew, Adjustable Carriage Stop
5	2	6358-0018	Nut, Hex, 1-8 UNC
6	2	8326-0018	Nut, Hex, Jam, 1-8 UNC

Cylinder Assembly

ITEM NO.	H	H	H	H	2	2	2	Model Used (typical)
	1	3	5	2	1	1	1	
	2	-	-	/				
	H	4	6	3				
	P	/	/	H				
		5	7	P				
		H	.	H				
		P	5	H				
			H	P				

Part Numbers							
1		X					2576-0000
1						X	8988-0010
1	X	X	X	X	X		2573-0000
1						X	8893-0010
2	X						2574-0000
2						X	8877-0013
2			X				2575-0000
2					X		8877-0009
2			X				3436-0000
2						X	8892-0009
3			X				8623-0000
3	X	X		X			2577-0000
4	X	X		X			2579-0024
4			X	X	X	X	8625-0024
5	X	X		X			2580-0000
5				X	X	X	9679-0008
5		X		X	X	X	8629-0000
6	X	X		X			2581-0000
6			X	X	X	X	8628-0000
7			X	X	X	X	8626-0020
7	X	X		X			2578-0020
8	X	X	X	X	X	X	Consult Factory
9	X	X	X	X	X	X	4544-0000
10			X	X	X	X	9266-0008
10	X	X		X			7216-0006
11	X	X	X	X	X	X	7260-0006
12			X				8624-0000

- Velocity Fuse
- Fitting, Elbow #10 O-ring x 1/2 fp
- Fitting, Elbow, 1/2m x 1/2f swivel
- Fitting, Elbow, STR THD 7/8-14
- Velocity Fuse
- Velocity Fuse
- Velocity Fuse
- Velocity Fuse
- Velocity Fuse
- Velocity Fuse
- Velocity Fuse
- Fitting, Coupling, Hex 1/2fp x 1/2fp
- Fitting, Reducer 1/2 x 3/8 f swivel
- Hose, High Pressure, 24'
- Hose, High Pressure, 24'
- Fitting, Tee
- Fitting, Tee Branch, 1/2 FFor x 1/2 FFor Swivel
- Fitting, Tee Run, FFOR 3/8 Ffor x 3/8mp
- Fitting, Elbow, 1/2m x 3/8f swivel
- Fitting, Elbow 3/8 Ffor x 1/2mp
- Hose, Low Pressure, 20'
- Hose, Low Pressure, 20'
- Cylinder
- Clevis Pin and Clips
- Fitting, Adapter, FFor 1/2 FFor x 3/4-6 Straight
- Adapter, 3/8 npt x 3/4-16 straight
- Fitting, Reducer 1/2 mp x 3/8 fp
- Fitting, Adapter, Ffor, 1/2 FFor x 1/2mp

**WARNING**

**DO NOT DISCONNECT OR SERVICE HYDRAULIC HOSES OR FITTINGS unless platform is fully secured or lowered**

D85

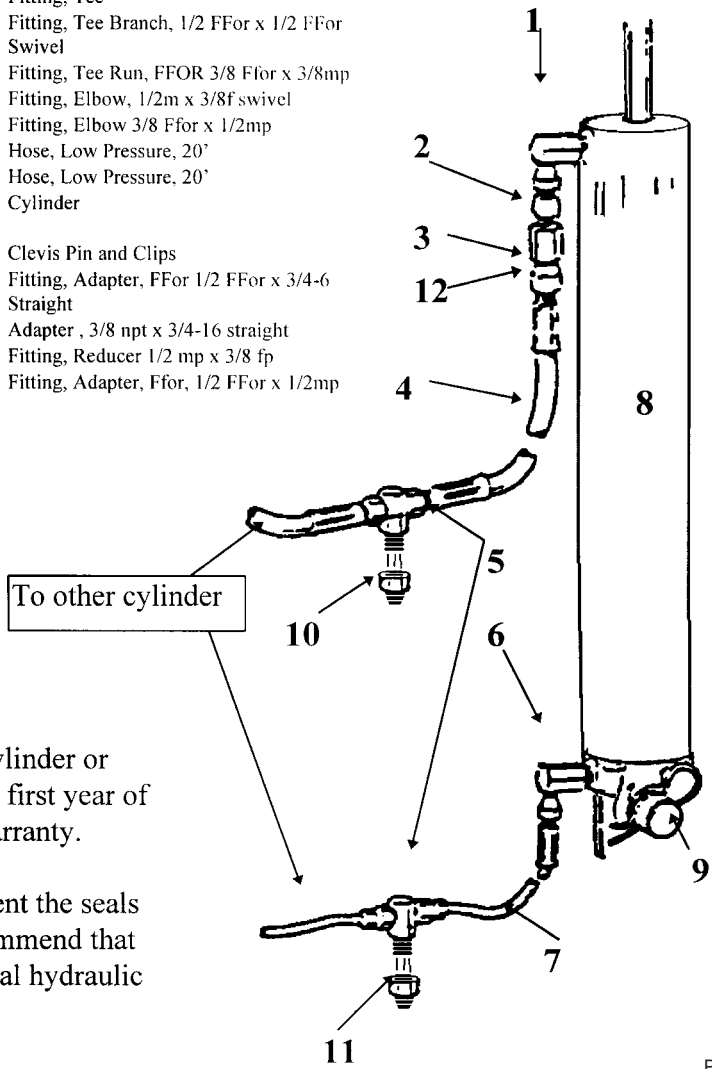

Note: Tampering with the cylinder or changing the seals within the first year of operation may void your warranty.

After the first year, in the event the seals need to be replaced, we recommend that you take the cylinder to a local hydraulic repair shop.

(THIS PAGE INTENTIONALLY LEFT BLANK.)

The **INTERLOCK** is a device used to mechanically prevent the gate from opening. Below are the standard types of interlocks supplied. As this is a safety device, replacement components are only available as shown below. Some configurations may vary by application.

**ANDERSON CABLE**

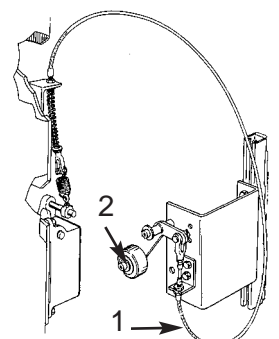

PFL-1885-6A

**GAL CABLE**

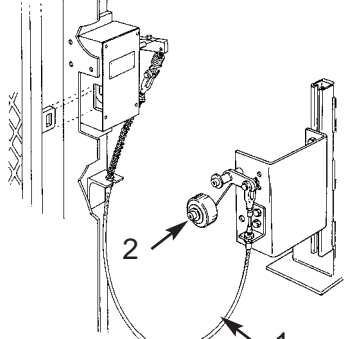

PFL-1885-7A

1. Control Cable Assembly  
10' - #9292-0120  
15' - #9292-0180  
25' - #9292-0300  
30' - #9292-0360
2. Roller Arm Assembly #9280-0000  
Wheel Only #9284-0040

**GAL (Left Hand Shown)**

RH #2690-0000  
LH #2691-0000

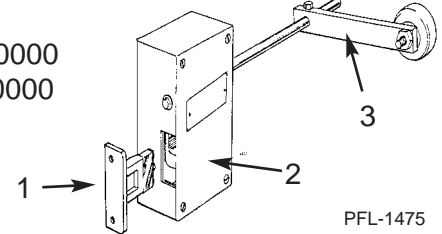

PFL-1475

1. Keeper #3838-0000
2. Contact Block (inside) #3832-0000
3. Arm w/Roller #4342-0000

**ANDERSON (Right Hand Shown)**

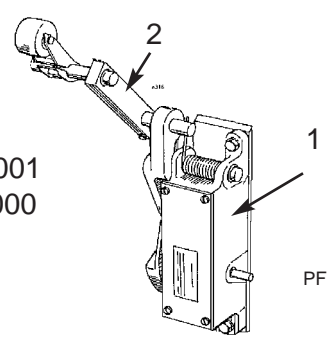

RH #2678-0001  
LH #2678-0000

PFL-1368

1. Contact Block (inside)
2. Arm #6950-0000

**ELECTRIC STRIKE**

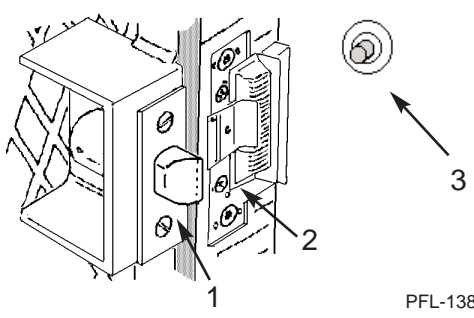

PFL-1389

1. Spring Latch #7566-0000
2. Strike #9169-0000
3. Button #9096-0000

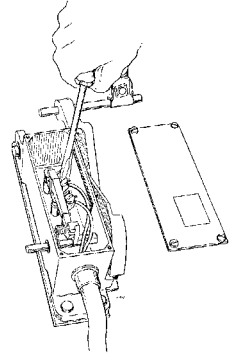
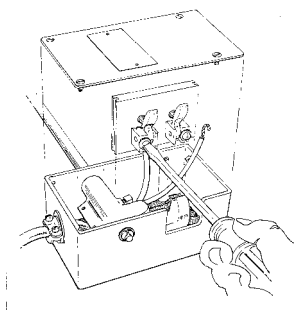
<p><b>ANDERSON</b></p>  <p style="text-align: right;">PFL-1401</p>	<p><b>GAL</b></p>  <p style="text-align: right;">PFL-1250</p>
--	--

See schematic for proper wiring instructions.

## 21 Series

A **GATE STATUS SWITCH** is supplied when the contacts are not being used. If required, it will be mounted to the gate post or header. Normally the GAL and Anderson interlocks do not use this switch. Specific order requirements may dictate otherwise.

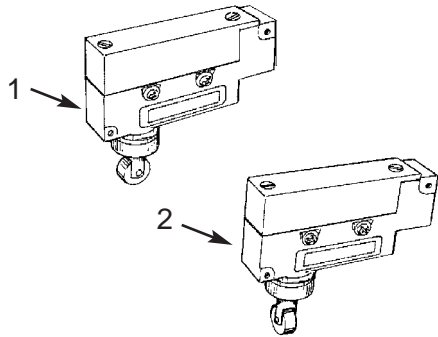

PFL-1293

1. Roller Plunger (parallel) #6220-0000
2. Roller Plunger (perpendicular) #6216-0000

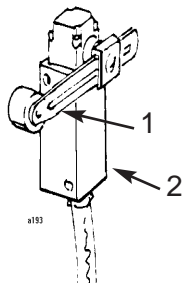

PFL-1205

1. Adjustable Roller Arm #2891-0005
2. Switch #2893-0005

# Recommended Storage Requirements

---

## RECOMMENDED STORAGE REQUIREMENTS

### ENVIRONMENT

All components should be stored indoors. The area of storage should be kept at a constant temperature above 55 degrees and relative humidity of approximately 40%, free from heavy dust and contaminants. Outdoor storage is NOT recommended.

### STACKING

Except for placing the parts container and bracing on the empty carriage, stacking of the various gate components is strictly forbidden. Enclosure and gate panels will warp. Objects on top of the columns may cause severe damage.

**LONG-TERM STORAGE**, more than two months after shipment, will require that the following maintenance procedures be performed every sixty days from date of shipment:

1. If CHAINS are stored for an extended period of time or in a corrosive environment, they may need to be dipped in a non-detergent oil to retain their original condition.
2. SPROCKETS should be coated lightly with a non-detergent oil to prevent corrosion.
3. SAFETY CAMS are a part of the WHEEL-BLOCK ASSEMBLY and should be lubricated with a non-detergent oil and rotated to ensure free operation.
4. The MOTOR PUMP UNIT must remain full of oil to prevent rusting of the reservoir.
5. CYLINDERS must be stored horizontally in a constant environment with all ends and ports capped and rotated 180 degrees every two months.
6. ELECTRICAL COMPONENTS should be plugged to prevent moisture and other contaminants from entering them. Store in a dry place to prevent corrosion.
7. PARTS CRATE must remain sealed and dry.

For units stored longer than six months, it is recommended that you contact the Product Support Department of Pflow Industries for additional information that may be available prior to starting up your unit.

Our warranty policy does not cover damage as a result of improper storage.

# 21 Series

## ELECTRICAL TERMINOLOGY AND APPLICATIONS

### Ruling Bodies:

NEMA - National Electrical Manufacturers Association - (National testing and manufacturing standards body of electrical apparatus.)

UL - Underwriters Laboratories, Inc. - (Independent testing laboratory - some cities require UL control panels and electrical apparatus.)

JIC - Joint Industry Council - (Advisory group to provide standards for production equipment, safety and dependability.)

NFPA - National Fire Protection Association - (Ruling board of NEC - sets national fire/safety standards for equipment/plants.)

CSA - Canadian Standards Association - (Regulatory agency of Canada - CSA required stamp on electrical devices in Canada.)

ANSI - American National Standards Institute - (Adopts code; sets committees.)

ASME - American Society of Mechanical Engineers - (Writes codes - Secretariat for ANSI.)

NEC - National Electrical Code - (Advisory board to NFPA - their recommendation/codes are usually adopted throughout the USA.)

OTHERS - GM, Ford, Dupont, etc. Customers may have special plant specifications incorporating several ruling bodies or their own electrical code specifications.

### Pflow's Standard

NEMA type 1 classification is a general purpose, indoor only, usage. Only COMMERCIAL users generally accept this type: i.e., retail stores, mini storage, warehouses, etc.

#### NOTE

*INDUSTRY does not accept (this NEMA type 1): i.e., auto manufacturing, chemical manufacturing, and paper manufacturing.*

All other Pflow units are NEMA 12 classification in regard to the controls, push button stations, and electrical design built under the following standards:

JIC: EMP-1 Electrical standards for mass production equipment.

JIC: Electrical standards for general purpose machine tools.

NFPA 79: Electrical standard for industrial machinery

NEMA type 12 classification is an indoor only usage with gasket protection from dust, dirt, fiber flyings, dripping water, and external condensation of non-corrosive liquids.

#### NOTE

*If JIC is to be strictly adhered to, they require that all devices be minimum NEMA 12, rigid conduit, specific wire coloring, etc. (controls and field wiring).*

#### NOTE

*You should note that the NEMA rating of equipment is based on the electrical device(s) with the lowest NEMA type.*

EXAMPLES: 1) If we provide a JIC NEMA 12 standard control package with an Anderson or VA gate interlock, our NEMA rating goes to NEMA type 1; and we lose our JIC rating. 2) If we provide a GAL interlock, which has exposed electrical contacts, we rate no NEMA rating and lose our JIC rating. 3) If we provide EMT conduit or don't provide the proper JIC electrical field wiring techniques, we lose our JIC rating.

### Outdoor Application

Outdoor units or electrical devices exposed to severe weather conditions should not be rated less than NEMA type 4. This is a watertight, dust-tight indoor-outdoor classification that will provide protection against splashing water, seepage of water, falling or hose-directed water, and severe external condensation.

### Corrosive Application

The Chemical Industry on the whole usually specifies a minimum NEMA type 4X. A NEMA 4X rating is similar to a NEMA 4 with added corrosion resistance.

## Hazardous Locations

Hazardous locations are an extremely specialized electrical classification. Few electrical experts exist in this field. All explosion-proof hazardous locations must be handled on an individual job site condition.

The NEC has three classes (I, II, III), - two divisions, (1 and 2) and seven group designations (A, B, C, D, E, F, and G).

### Class Definitions:

**CLASS I Locations:** Those in which flammable gasses or vapors are or may be present in the air in quantities sufficient to produce explosive or ignitable mixtures.

**CLASS II Locations:** Those where the presence of combustible dust presents a fire or explosion hazard.

**CLASS III Locations:** Those where easily ignitable fibers or flyings are present but not likely to be suspended in the air in quantities sufficient to produce ignitable mixtures.

### Division Definitions:

**DIVISION 1** is an extremely dangerous explosive condition that exists normally.

**DIVISION 2** is a dangerous explosive condition that could exist but usually does not.

**GROUP** designations are given by the NFPA, State Fire Marshals, insurance companies or consulting engineering firms according to the gasses/dust, etc. in the area and the spark or temperature needed to produce an explosion.

Currently, in order to provide competitive pricing in the hazardous location area, we are producing "intrinsically safe" control packages. Intrinsically safe is defined as: electrical devices provided cannot produce a spark or temperature hot enough to ignite the surrounding gasses/dust, etc.

## Optional Control Packages and Devices for Hazardous Locations

NEMA type 7, Class I, Division 1 and 2, Group A, B, C, or D enclosures shall be capable of withstanding the pressures resulting from an internal explosion of specified gas and shall contain such an explosion sufficiently so that an explosive gas mixture existing in the atmosphere will not be ignited.

NEMA type 9 is similar to NEMA type 7 but is rated for dust ignition-proof - Class II, Division 1 and 2, Groups E, F, or G.

# Warranty

---

<b>PARTS</b>	
Structure .....	Lifetime
Manufactured Components.....	One Year
Purchased Components .....	One Year

<b>LABOR</b>	
Structure .....	Lifetime
Manufactured Components .....	One Year
Purchased Components .....	90 Days

## The Small Print

The warranty period begins 30 days after shipment. All warranty work must be pre-authorized by Pflow Industries' Product Support Department prior to starting work. All billing must be in accordance with our Warranty Procedures. Replacement of defective parts will be handled in accordance with Pflow's Return Goods Authorization policy. If Pflow Industries determines that equipment failures were caused by abuse, improper installation, or lack of maintenance, they will not be covered. Pflow Industries will not accept consequential losses (missed production, etc.), premium time labor, or air freight charges. Manufactured items are defined as those components manufactured and/or assembled by Pflow. Structure is defined as columns and carriage (excluding carriage side guards). Purchased items are those components that are used as supplied by vendors. Gates and enclosures are excluded and covered for 90 days parts and labor. This warranty applies to all models and may not be modified or extended except by written authorization from Pflow Industries, Inc.

We, the manufacturer, sincerely hope that you do not experience problems with the equipment. If you do, the following procedures should be followed:

## Pre-Authorization

Pflow Industries must be notified of the problem before we can authorize the repair. We need to determine the cause of the problem, who should be doing the work, and what is involved. If it is our decision to have your organization or your subcontractor do the work, you will be given an authorization number which must be referenced on all subsequent paperwork. During our non-working hours, we ask that you notify us by phone or FAX during the next business day.

Issuance of an authorization number does not guarantee approval and/or payment.

## Invoices

1. You have 30 days from the date the work was completed to submit an invoice for approval. If approved, payment is made 30 days from the date of approval.
2. A deduction from outstanding payments to Pflow for warranty is NEVER authorized and will result in a 10% processing fee.
3. Invoices received without sufficient information will be returned. They will be reconsidered for approval when complete documentation is received. All invoices must include, in detail, the following:
  - Description of problem;
  - Pflow serial number;
  - Labor hours per problem;
  - Rate per hour;
  - Travel time incurred;
  - Date work was performed;
  - Copies of receipts for materials purchased locally or labor subcontracted.

## Comments

Pflow Industries is not responsible for payment made on claims prior to our approval.

Local purchase of components must be pre-authorized.

Where distance and/or experience may be more cost-effective, Pflow Industries reserves the right to use alternate organizations.

Labor is defined as a maximum of two hours travel per call, plus reasonable on-site repair time as determined by Pflow Industries.

# Installation Questionnaire

*We want to provide equipment that is built correctly and shipped complete. To achieve that, we need to know what errors are being made or what field problems you are experiencing. Please answer the following questions and return this form to the Product Support Department at Pflow Industries, Inc. If more space is required for comments, please use the reverse side.*

1. Was the unit received in good condition? Yes / No

If not, please describe damage: \_\_\_\_\_

2. Was the unit received complete? Yes / No

If not, what was missing? \_\_\_\_\_

3. Was the lift manufactured correctly? (Did it match the GA drawing?) Yes / No

If not, please describe the errors: \_\_\_\_\_

4. Did the unit (i.e., lift, gates, enclosures) fit? Yes / No

If not, please describe in detail the problem areas: \_\_\_\_\_

5. Did you return after the electrical was completed for final adjustments, testing, and training?

Yes / No

If No, were you able to hook up temporary power to test the unit and make all final adjustments?

Yes / No

If Yes, were there electrical problems that you were aware of?

Was there a problem with the components? Yes / No

If yes, please describe: \_\_\_\_\_

Was there a problem with the field wiring? Yes / No

If yes, please describe: \_\_\_\_\_

6. Did you test the unit to full capacity? Yes / No

7. Did you test all gates to make sure that the unit does NOT operate if they are open? Yes / No

8. At each level, when the carriage is NOT present, can you open the gate? Yes / No

Comments: \_\_\_\_\_

Pflow Job #: \_\_\_\_\_ Customer/User: \_\_\_\_\_

Questionnaire Completed By: \_\_\_\_\_ Date: \_\_\_\_\_

Company: \_\_\_\_\_ Phone: \_\_\_\_\_

PFLOW INDUSTRIES, INC., 5045 N. 35th Street, Milwaukee, WI 53209

Phone (414) 462-8810; Fax (414) 462-2673; 040199

# Acceptance Certification

---

*We accept this equipment as being properly installed, tested, and performing to our satisfaction. This form covers both the mechanical and electrical installation of the equipment and is for the purpose of quality assurance by Pflow Industries, and in no way releases either Pflow Industries, Inc. or the installing contractor(s) of their warranty obligations. If there are any exceptions or unresolved items, please note.*

---

---

**JOB NO.:** \_\_\_\_\_ **JOB NAME:** \_\_\_\_\_

Site Mailing Address: \_\_\_\_\_

City, State, Zip Code: \_\_\_\_\_

On-Site Contact for future follow-up:

Name: \_\_\_\_\_ Title: \_\_\_\_\_

Phone: (\_\_\_\_) \_\_\_\_\_ - \_\_\_\_\_ Ext. \_\_\_\_\_

-----  
**Tests Successfully Performed:** \_\_\_\_\_ Load test at \_\_\_\_\_ % of capacity \_\_\_\_\_ Operation  
\_\_\_\_\_ Gate/Interlock Operation Other: \_\_\_\_\_

-----  
**Personnel Instructed on the Operation:**

Name: \_\_\_\_\_ Company: \_\_\_\_\_

Name: \_\_\_\_\_ Company: \_\_\_\_\_

-----  
**ACCEPTED BY:**

Date: \_\_\_\_\_

Name: \_\_\_\_\_

Name: \_\_\_\_\_

Title: \_\_\_\_\_

Title: \_\_\_\_\_

Company: \_\_\_\_\_

Company: \_\_\_\_\_

Phone: \_\_\_\_\_

Phone: \_\_\_\_\_

-----  
**PFLOW PERSONNEL / REPRESENTATIVE / INSTALLER PRESENT:**

Name: \_\_\_\_\_ Company: \_\_\_\_\_

Please return a copy of this form to the Product Support Department.

PFLOW INDUSTRIES, INC., 5045 N. 35th Street, Milwaukee, WI 53209  
Phone (414) 462-8810; Fax (414) 462-2673; 040199



