

RUNNING CLEARANCES

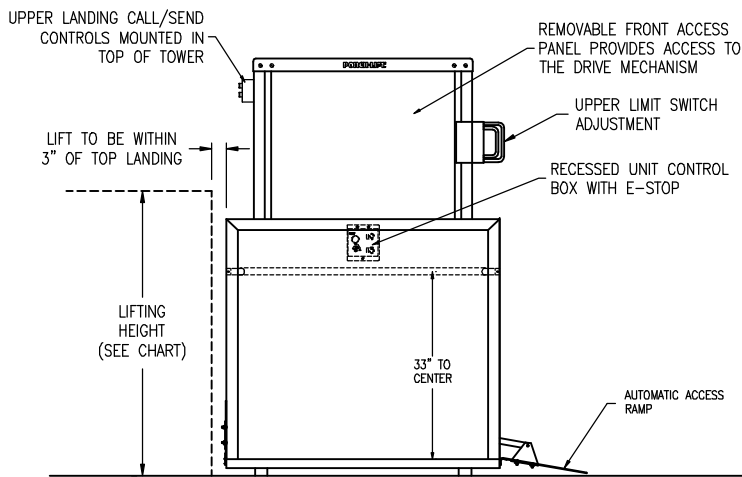

FRONT ELEVATION

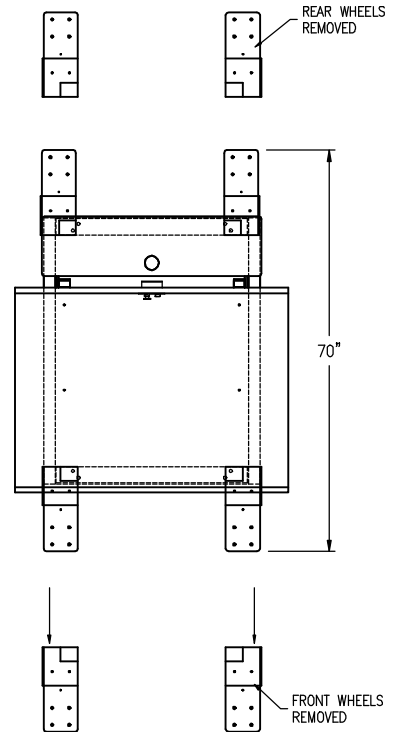
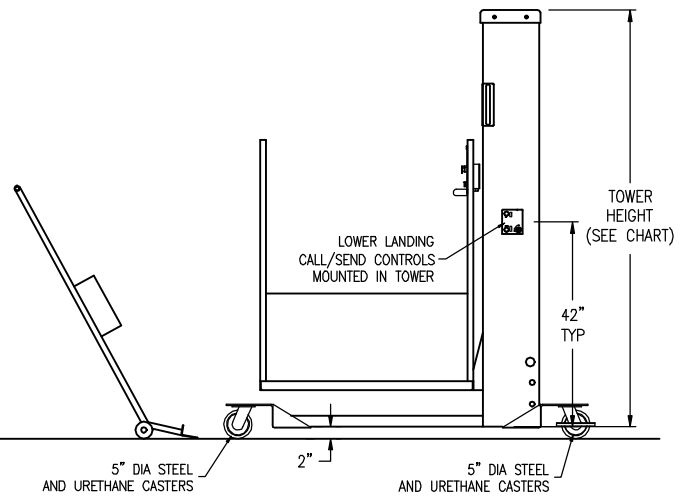

LOWER LANDING SIDE ELEVATION

NOTE:
WHEELS MUST BE REMOVED BEFORE UNIT IS PUT INTO OPERATION.

MODEL	Max. Lifting Ht.	Tower Height
36"	36"	59.25"
50"	50"	73.25"
72"	72"	95.25"

 4001 East 138th Street GrandView, MD 64030-2837			MODEL:		
			DEALER:		
PORCH-LIFT. VERTICAL PLATFORM LIFT PL-P Portable Straight-thru Platform			CUSTOMER:		
			JOB or P.O.#:		
SCALE:	DATE:	ORDER NUMBER: PL-PORT			