

Evolution

Limited Use/Limited Application Elevator

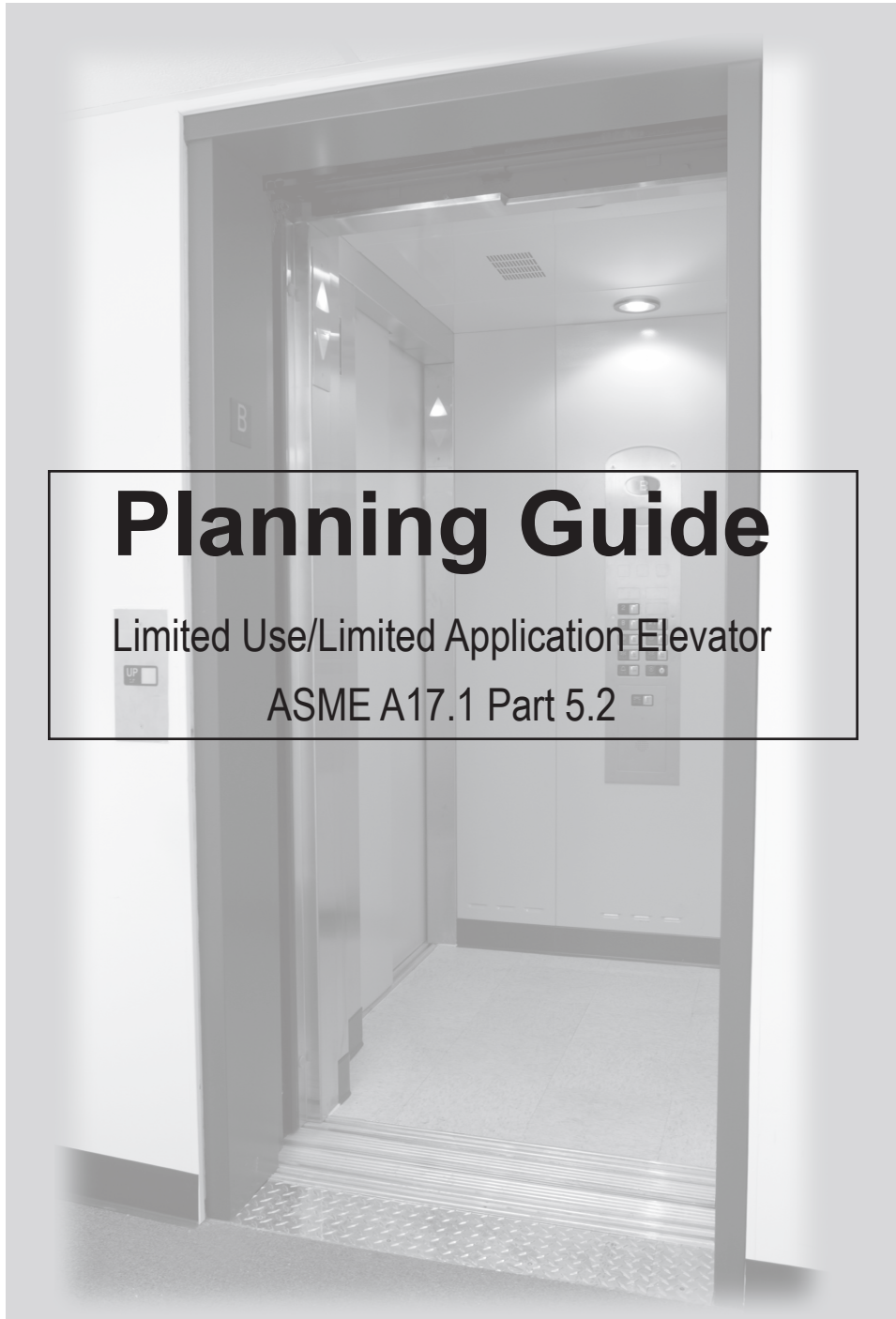

Planning Guide

Limited Use/Limited Application Elevator
ASME A17.1 Part 5.2

August 2008

National Wheel-O-Vator
A Division of ThyssenKrupp Access



ThyssenKrupp

INTRODUCTION

The EVOLUTION elevator is designed to help solve accessibility problems in commercial buildings and meet state and national codes covering the Limited Use/Limited Application (LU/LA) elevators, when properly equipped and installed.

We strongly recommend you contact the code authority having jurisdiction in the area(s) where the equipment will be installed. It is extremely important for you to know and adhere to all regulations concerning installation and use of elevators.

IMPORTANT NOTICE:

This Planning Guide provides nominal dimensions and specifications useful for INITIAL planning of an elevator project. BEFORE beginning actual construction, be sure to receive application drawings customized with specifications and dimensions for your specific project.

Elevator configurations and dimensions are in accordance with National Wheel-O-Vator's interpretation of the standards set forth by ASME A17.1-2007 Part 5.2. Please consult National Wheel-O-Vator or the EVOLUTION dealer in your area for more specific information pertaining to your project, including any deviation between referenced standards and those of any local codes or laws.

The dimensions and specifications in this Planning Guide are subject to constant change (without notice) due to product enhancements and continually evolving codes and product applications.

Steps of planning for an Evolution LU/LA Elevator from National Wheel-O-Vator:

1. Determine customer's intention for use. (This is a Limited Use/Limited Application Elevator and is restricted in size, capacity, speed and rise.)
2. Determine code requirements of site. (Local Jurisdictions may have requirements other than or in addition to ASME A17.1-2007 Part 5.2)
3. Determine installation parameters of the site.
4. Determine the car type from the hoistway requirement pages.
5. Determine the interior size of the car.
6. Use the appropriate chart to determine the hoistway requirements.
7. Use page 5 to plan for machine room and electrical requirements.
8. Use page 6 to plan for hoistway door requirements.

Contents

Standard and Optional Equipment	3
Hoistway Requirements.....	4 - 5
Typical Machine Room Layout	5
Automatic Sliding Door Details	6
Rail Reactions	6
Evolution Elevator Specifications	7

STANDARD EQUIPMENT FOR LU/LA

The Evolution elevator is designed to meet the requirements of ASME A17.1 Part 5.2, when properly equipped and installed.

Mechanical Equipment:

- 1:2 roped hydraulic single stage cylinder with line rupture valve
- 5 hp submersible motor with two speed valve assembly
- 208/230V, 60 Hz, 30 amp single phase power supply
- 8 lb. T-rail system
- Two 3/8" diameter wire rope cables
- Sling assembly
- Forged rope sockets
- Buffer springs and stands

Car and Appointments:

- Car sized to your application
- Autumn white interior metal panels
- Matching ceiling panel
- Unfinished fire rated wood floor
- Dual recessed car lights
- Recessed telephone box (telephone by others)
- Toeguard on entrance
- Handrail - Stainless steel finish

Car and Hoistway Doors

- Fully automatic, side opening sliding car door: 36" x 80" door with two side opening sections with electric contacts. Door is equipped with battery backup and adjustable opening and closing speeds.
- Fully automatic, side opening, sliding hoistway doors: 36" x 80" doors with side opening sections in a steel frame, with electromechanical locks. Door carries a 1 1/2 hour fire rating. Door and frame have a primed finish.

Controls:

- Selective micro processor controller
- Stainless steel control operating panel
- Battery backup emergency light and alarm
- Automatic homing to any floor with adjustable timing
- Illuminated alarm switch
- Automatic interior lights
- Keyed car emergency stop switch
- Car top inspection station
- Full height photo electric screen
- Car mounted digital floor indicator
- Arrival and passing signal

Safety Devices:

- Automatic battery powered and manual emergency lowering devices
- Upper and lower terminal limits
- Overspeed governor or overspeed valve
- Manual reset slack rope safety
- Dual direction leveling
- Anti-creep device
- Pit switch
- Pit clearance device (where required)
- Minimum pressure switch
- Pump run timer

General:

- Rated load: 1400 lbs.
- Speed: 30 fpm
- Data plates, capacity tags and rope tags
- Presentation drawings

OPTIONAL EQUIPMENT

Car:

- Car Interior Panels
 1. Metal (White, Gray, Pearl White, Txt Brown, or Txt Black)
 2. Applied laminate
 3. Wood and stainless steel
- Suspended ceiling

Controls:

- Keyed car control switch
- Keyed landing control switch

Miscellaneous:

- Pit ladder
- 32" doors
- Tank heater
- ADA compliant phone
- Phase 1 and 2 fire service
- 42" x 60" or 48" x 54" car size
- Hoistway access key (required by code in some jurisdictions)

HOISTWAY REQUIREMENTS

The drawings shown below illustrate the standard car size of 42"x 54" with 36" doors. Car sizes for Types 3 and 4 are 51' x 51". (All dimensions are shown in inches.) Optional car sizes of 42" x 60" and 48" x 54" are also available. Consult National Wheel-O-Vator for hoistway details.

Note: To comply with ICC/ANSI A117, the minimum car size for new construction is 42" x 54".

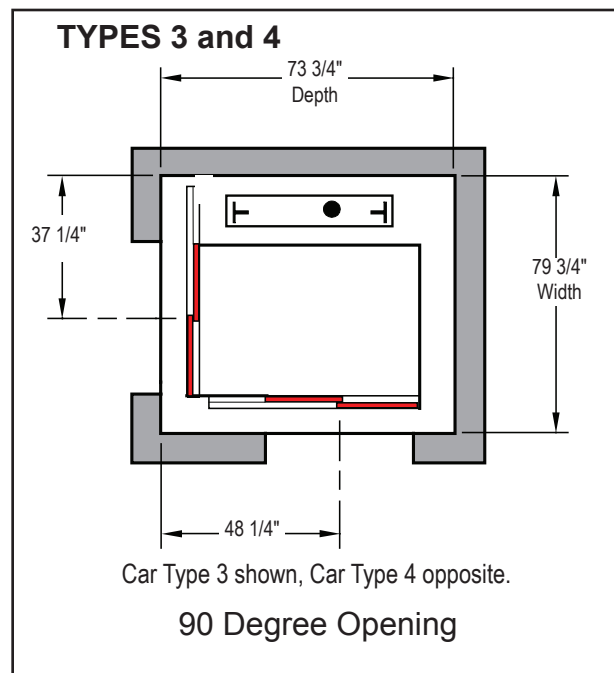
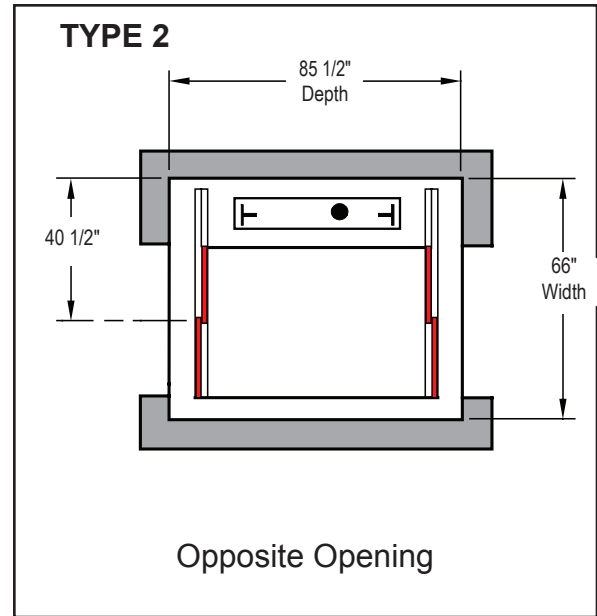
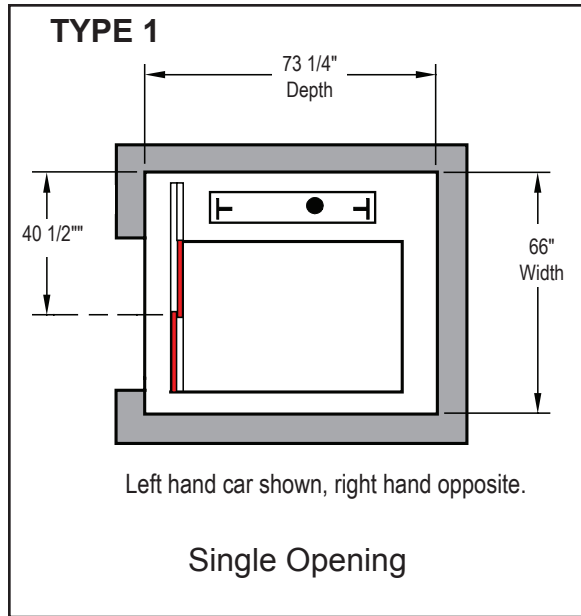

Hoistway Notes:

- A load bearing wall is required to sustain rail reactions. See page 6 for rail reactions.
- The hoistway pit floor must resist a dynamic force of 5800 lbs.
- 132" overhead clearance is required above the top landing floor.
- 14" minimum pit. (A Pit Clearance Device is required to attain required refuge space).
- Hoistway sizes reflect running and access clearances only. Consult your local authority to assure compliance with state and local codes.
- The hoistway is required to be free of all pipes, wiring, and obstructions not related to the operation of the elevator.

TYPICAL MACHINE ROOM LAYOUT

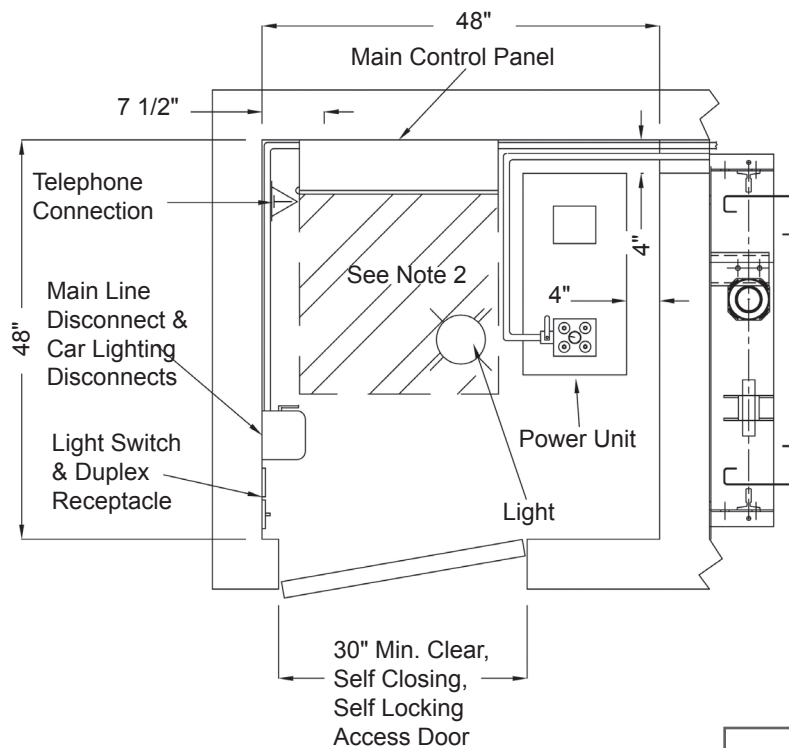

Notes: All Dimensions are in inches unless specified.

1. Local, state, and national codes must always be followed.
2. 36" minimum clearance in front of the control panel is required by N.E.C.
3. Disconnect switches and light switch are to be located on the strike side of the machine room door.
4. The main line disconnect is to be fused and capable of being locked in the open position.
5. The car light disconnect is to be capable of being locked in the open position and have over current protection means in the machine room.
6. The pump unit should not be over 40' away from the cylinder.
7. The minimum clear room headroom is 84".
8. Room temperature is to be maintained between 50 and 90 degrees Fahrenheit.
9. Humidity is to be maintained at 5% to 95% non-condensing.

Main line disconnect and car light disconnect by others

Main Line Disconnect
3 Poles single phase
(1 for battery lowering)
3 Poles three phase with auxiliary contact for
battery lowering

Car Light Disconnect
1 Pole

Main Control Box
24"H x 24"W x 8"D

Submerged Power Unit
35"H x 24"W x 12 1/2"D

FULLY AUTOMATIC, SIDE OPENING, SLIDING CAR AND HOISTWAY DOOR

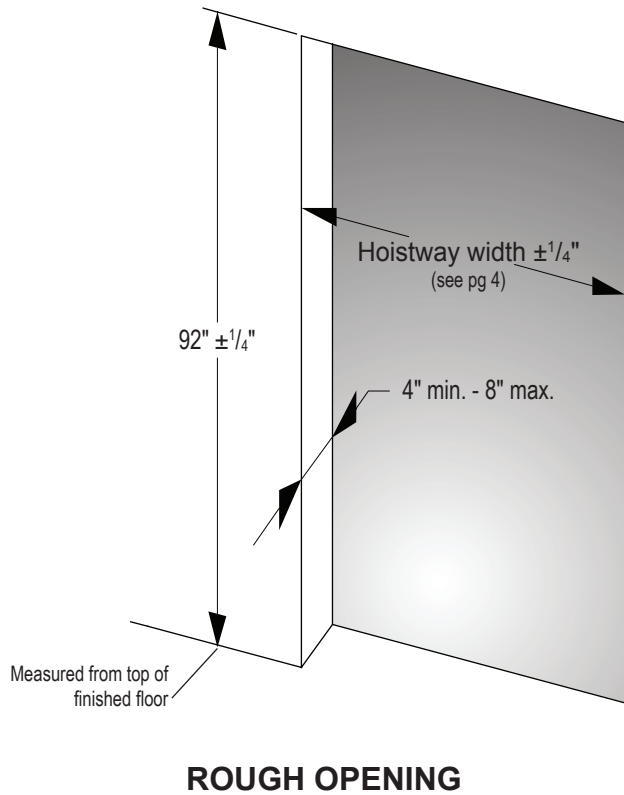

Notes:

1. All dimensions are shown in inches.
2. See hoistway requirements for the location of the door centerline.
3. Door panels and frame are primer gray.
4. **Elevator must be installed before rough opening is finished.**

RAIL REACTIONS

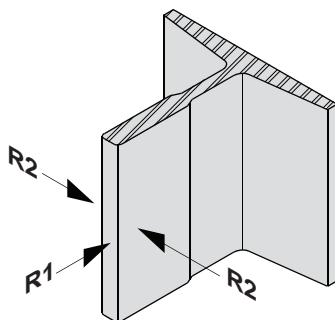

R1=135 LBF.

R2=766 LBF.

Rail reactions do not include safety factors. Applicable safety factors must be considered in hoistway design.

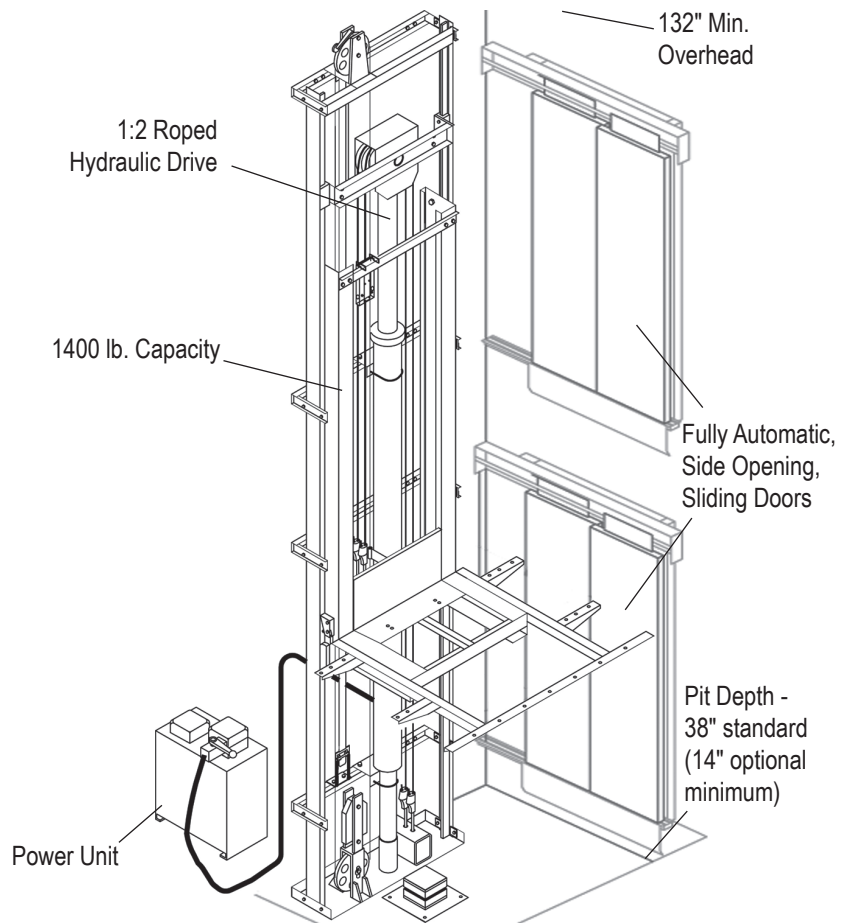

EVOLUTION ELEVATOR SPECIFICATIONS

Division 14 20 00

Limited Use/Limited Application Elevator

PART 1 GENERAL

1.01 SECTION INCLUDES:

- A. Limited Use / Limited Application (LU/LA) commercial elevator with 1:2 roped hydraulic lift system.

1.02 WORK INCLUDED:

- A. Furnish all labor and materials, equipment and incidentals necessary to assemble and erect the commercial elevator, complete with a remote power unit and all hoses, rails, brackets, connections and controls essential for proper operation.

1.03 WORK BY OTHERS:

- A. Hoistway: Construct a hoistway of the size required by the manufacturer, complete with all demolition, additional framing, headers and framing components necessary to prepare the existing building to receive the elevator.
 - 1. Hoistway size: 66" W x 73 1/4" D (dependant upon car size)
 - 2. The hoistway shall be vertical to within 1/8" throughout the entire height.
 - 3. Provide structural members, installed, full length vertically of hoistway between floor plates per manufacturer's recommendation.
 - 4. Pit requirements: Provide 38" deep pit; using an alternative means device the pit depth may be reduced a minimum 14". Install reinforcement and concrete as necessary. Floor must sustain load specified in job drawings.
 - 5. Overhead clearance: 132" new construction; 114" w/ alternate means clearance device for existing construction.
- B. Construct a machine room:
 - 1. Provide elevator electrical circuit appropriate for particular motor, such as: 208/230 volt AC/ single or three phase / 60hz (30 amp).
 - 2. Provide elevator lighting electrical circuit: 115 volt (15amp)
- C. Provide system to maintain hoistway and machine room temperature between 50-90 degrees Fahrenheit.

1.04 REFERENCES:

- A. General: The applicable provisions of the following standards shall apply as if written here in their entirety.
- B. American Society of Mechanical Engineers / American National Standards Institute (ASME/ANSI) publications:
 - 1. ASME/ANSI A17.1, Section 5.2.
 - 2. ICC/ANSI A 117.1
- C. National Fire Protection Association (NFPA) publications:
 - 1. NFPA 70 National Electrical Code
 - 2. NFPA 101 Life Safety Code

1.05 SYSTEM DESCRIPTION:

- A. Travel: _____ (25' max)
- B. Stops: _____ (up to 6)
- C. Load Capacity: 1400 lb
- D. Speed: 30 fpm

1.06 SUBMITTALS:

- A. Submittals shall be in accordance with Section 01300, SUBMITTALS.
- B. Product Data: Submit product data, including manufacturer's specifications.
- C. Submittal Drawings:
 - 1. Submittal drawings showing all field construction, including dimensions.
 - 2. Hoistway dimensions
 - 3. Color selection charts

1.07 QUALITY ASSURANCE:

- A. Qualifications:
 - Installer Qualifications: A company experienced in the assembly and erection of lifts and LU/LA elevators of the type specified; trained and certified by the manufacturer.
 - Manufacturer Qualifications: A company specializing in the manufacture of lifts for the disabled and LU/LA elevators.
- B. Regulatory Requirements: The complete manufacture, fabrication and erecting of the elevator shall be in compliance with all Federal, State and local codes and ordinances. The installer shall verify requirements of the local authority having jurisdiction and shall comply with all local codes and ordinances

1.08 DELIVERY, HANDLING & STORAGE:

- A. All components shall be shipped to the site in substantial crates to protect from damage during shipping and handling. Upon arrival, inspect components and keep under cover until installed.

1.09 WARRANTY:

- A. Unit shall have a two (2) year Limited parts warranty.

1.10 MAINTENANCE:

- A. Maintenance of the LU/LA elevator shall consist of regular cleaning and inspection at intervals not longer than every 6 months.
- B. Inspection: ASME A17.1 requires all LU/LA elevators to be inspected every 6 months.

PART 2 PRODUCT

2.01 MANUFACTURER

- A. Provide the Evolution elevator manufactured by National Wheel-O-Vator, a division of ThyssenKrupp Access.
- B. No substitution shall be considered unless written request for approval has been submitted and received by the architect at least ten (10) days prior to the bid date.

2.02 COMPONENTS

- A. Car:
 - 1. Size: 42" W x 54" D Clear (others available)
 - 2. Enclosure: Shall be securely fastened to the car frame and platform. Shall be constructed of formed sheet steel panels with powder coated finish. Floorboard shall be constructed of 1-1/2" AC plywood with fire retardant coating.
 - 3. Car entrances: Shall be equipped with D.C. powered automatic operator, horizontal sliding steel doors, automatic reopening system and clutch for hoistway door pick-up.
 - 4. Safety Screen: Doors have full height safety light screen.
 - 5. Car Doors: Shall be 36" x 80" with powder coated finish.
- 6. Handrail: Provide one stainless steel handrail located on the car wall and mounted in accordance with ICC/ANSI A117.1 requirements.
- 7. Telephone: Provide ADA "Hands Free" phone mounted in control panel
- 8. Control panel: Provide one momentary pressure illuminated button for each landing, keyed in car stop switch, alarm button, all mounted in a control panel having a removable stainless steel cover. Panel shall be designed and mounted so buttons are located in accordance with ICC/

(continued on next page)

Evolution LU/LA

ANSI A117.1 requirements.

9. Visual feedback: Provide digital floor position indicator in control panel, indicator lights acknowledging call for car, and arrow lights indicating car's next travel direction.
 10. Standard Color: Autumn White
 11. Audible feedback: Provide audible signal indicating car arrival and direction of travel.
 12. Tactile feedback: Provide tactile/Braille characters on all car and hall call push buttons, and hoistway door jambs
 13. Interior lighting: Provide overhead light fixtures that automatically turn on when the car is in operation and turn off by means of a timer circuit
- B. Hoistway entrances:
1. Design: Provide each entrance with an automatic operating, horizontal sliding door in frame.
 2. Construction: Doors and frames are steel with primed finish.
 3. Fire rating: Hoistway doors and frame shall be UL certified for 1 ½ hour fire rating.
 4. Doors shall have a concealed locking device, interlocked with the car operation to interrupt electrical power when the door is not securely closed. The entrance door shall be locked until car door opens.
- C. Hydraulic power unit:
1. The pump, submerged motor and valve shall be pre-wired, ready for connection to the controller in the field.
 2. Up direction acceleration adjustment.
 3. Two speed operation.
 4. Adjustable pressure relief valves.
 5. Manually operated down valve for emergency operation.
 6. Pressure gauges and pressure gauge isolation valves.
 7. Manual valve isolation between pump unit and jack.
 8. Low-pressure switch provided.
 9. Testing: Shall be factory tested prior to shipment.
- D. Cylinder:
1. Construction: Steel pipe with cylinder head having an internal guide ring and self-adjusting packing.
 2. Safety valve: Cylinder shall be equipped with a pipe rupture safety valve to prevent uncontrolled car descent.
- E. Plunger:
1. Construction: Shall be a machined steel shaft equipped with a stop, electrically welded to bottom end, to prevent plunger from leaving shaft cylinder.
 2. Diameter: 90 mm.
- F. Cable system: 1:2 system using (2) 3/8" – 7x19 aircraft cable integrated with rams header sheave mounted to the plunger.
- G. Guide rail: Shall consist of two 8-lb. T-rails assembled and fastened. Provide brackets to hold rail assembly to walls. Rail shall be furnished with steel splice plates and hardware.
- H. Car frame: Shall be equipped with non-metallic faced roller guide wheels.
- I. Leveling device: Provide Hall effect switch system to maintain car within ¼" of the landing.
- J. Control systems: Selective collective microprocessor. System components, i.e. car top box and main control panel shall be U.L. listed.
- K. Motor (submerged): 5.0 HP, 1750-RPM 208/230 VAC, single phase, (three phase available).
- L. Wiring:
1. Provide flexible traveling cable for electrical lights and controls in car.
 2. All other electrical wiring shall be insulated, flame retardant and moisture proof copper wiring, installed in flexible metal conduit.
- M. Safety Devices:
1. Slack cable protection: Provide a stainless steel linkage device that stops and sustains the car in the event of breakage or slacking of cables.
 2. Terminal stopping device: Shall be provided at the top and bottom of the car travel.
3. Over speed protection: Provide a device, which in the event of the car over speeding, stops and sustains the car at that position.
 4. Provide a platform toe guard at the car entrance.
- N. Two battery emergency operation system:
1. Powers a light in the car.
 2. Powers an emergency alarm system.
 3. Powers a system to allow car to descend to bottom terminal floor.
 4. The batteries shall be a re-chargeable type complete with an automatic re-charging system.

2.03 ACCESSORIES

Specifier Note: - Due to the individual nature of elevator installations, accessories such as, but not limited to, those in the following list are available:

- A. Car color.
- B. Hoistway door and frame color
- C. Finished flooring.
- D. Hydraulic tank heater.
- E. Electrical disconnect.

PART 3 EXECUTION

3.01 INSTALLATION

- A. Inspect the hoistway and determine if the hoistway meets the manufacturer's requirements for clearances and plumb.
- B. All components shall be assembled and erected in strict compliance with manufacturer's printed instructions.
- C. All wiring shall be in accordance with the wiring diagram furnished by the manufacturer.

3.02 FIELD QUALITY CONTROL

- A. Static/Running Load Test: All load rating and safety factors shall meet or exceed those specified in ASME A17.1

3.03 ADJUSTING

- A. Test the elevator to assure proper operation under all conditions of use. Make proper adjustments and review operating components for proper operation.

National Wheel-O-Vator

A Division of ThyssenKrupp Access

ThyssenKrupp Access Manufacturing, LLC

509 W. Front Street Roanoke, IL 61561

Ph# 800-968-5438 Fax# 309-923-9544

www.wheelovator.com